

HYDRAULIC WOOD CHIPPER *Assembly*

Model: TX1000

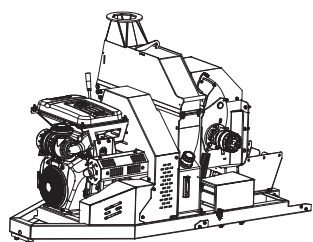

Engine and base frame

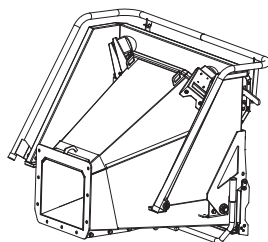

In-feeding chute

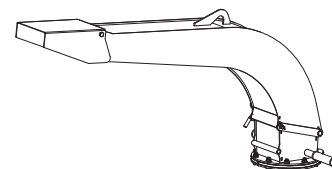

Lower discharging chute

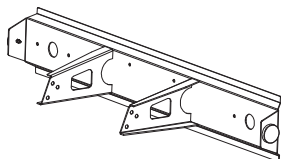

Taillight holder

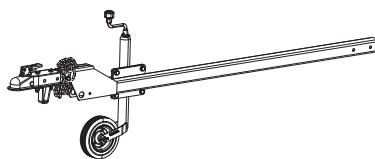

Tow Bar and Jockey Wheel

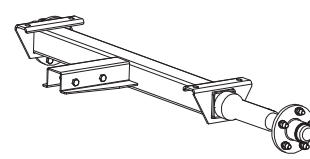

Axle

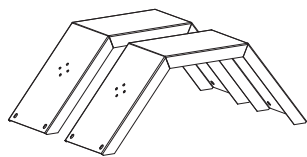

Mudguard

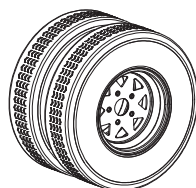

Wheels





Connecting rod

01. Axle

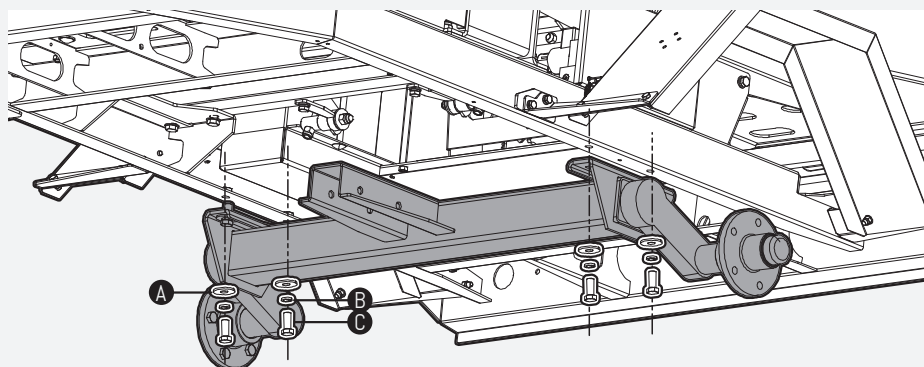
Install the axle onto the base frame and secure it using M12×30 full-thread hex head bolts (C), Spring washers 12 (B), and Flat washers 12 (A).



A Flat washer 12	 x 4
B Spring washer 12	 x 4
C Hex bolt M12 X 30mm	 x 4

02. Tow Bar and Jockey Wheel

Next, attach the tow bar and jockey wheel to the base frame using M12×90 hex head bolts (C), M12 hex lock nuts (B), and Flat washers 12 (A).

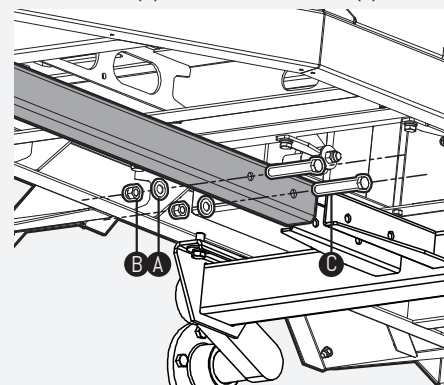

A Flat washer 12	 x 2
B Hex lock nut M12	 x 2
C Hex bolt M12 X 90mm	 x 2

Begin by securing the tow bar and jockey wheel using the tow bar clamp. Use M12×35 full-thread hex head bolts (C), along with flat washer 12 (A) and Spring washer 12 (B).

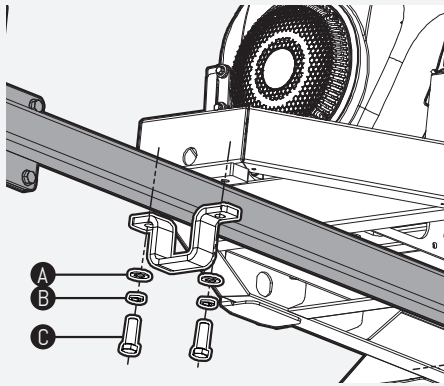

A	Flat washer 12		x 2
B	Spring washer 12		x 2
C	Hex bolt M12 X 35mm		x 2

03. Wheels

Install the tire onto the wheel axle using an M12 hex lock nut (A).

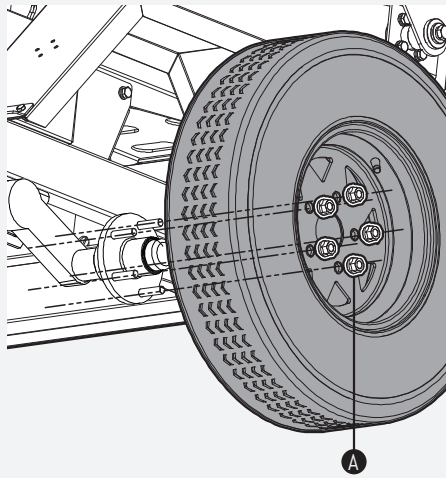

A	Hex lock nut M12		x 5
----------	------------------	---	-----

04. Lower discharging chute

Use M10×40 full-thread bolts (C), M10 hex jam nuts (B), and flat washers 10 (A) to assemble the lower discharging chute to the base frame.

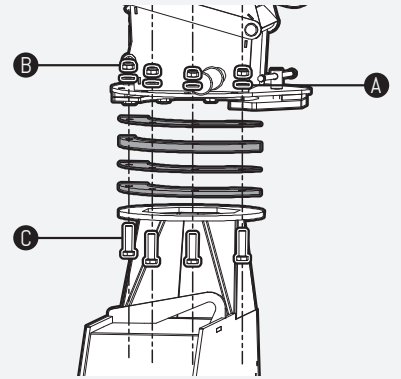

A	Flat washer 10		x 4
B	Hex lock nut M10		x 4
C	Hex bolt M10 X 40mm		x 4

05. In-feeding chute

Assemble the in-feeding chute to the base frame using a thin hexagon lock nut M10, a full - thread hexagon - head bolt M10×30, a plain washer Class C 10 and a spring washer 10.

Then use a full - thread hexagon - head bolt M10×25, a spring washer 10 and a plain washer Class C 10 for fixation.

Fix both ends of the connecting rod to the positions shown in the figure using a pin of Type B 8×26, a plain washer 8 and a split pin 2×20.

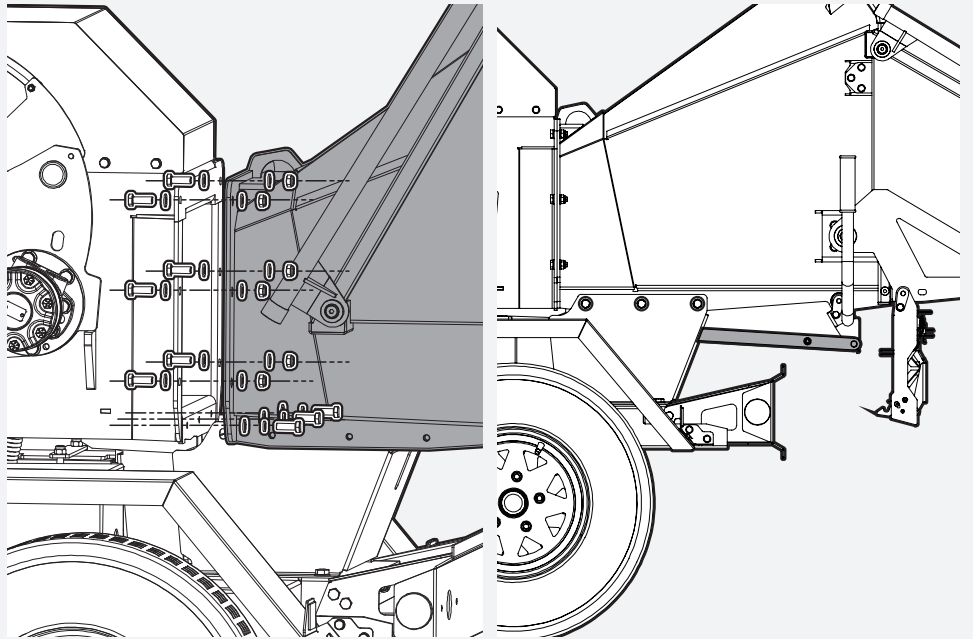

A	Hex bolt M10 X 25mm		x 6
B	Flat washer 10		x 6
C	Spring washer 10		x 6
D	Hex lock nut M10		x 4

06. Fender

Assemble the fender to the base frame through the fender assembly using an M8×20 full-thread hexagon head bolt (C), M8 hex lock nut (B), and Flat washer 8 (A).

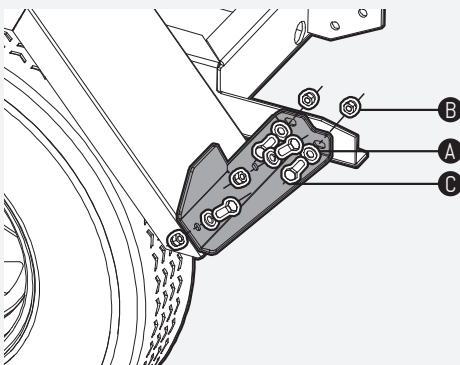



A	Flat washer 8		x 16
B	Hex lock nut M8		x 16
C	Hex bolt M8 X 20mm		x 16

07. Taillight holder

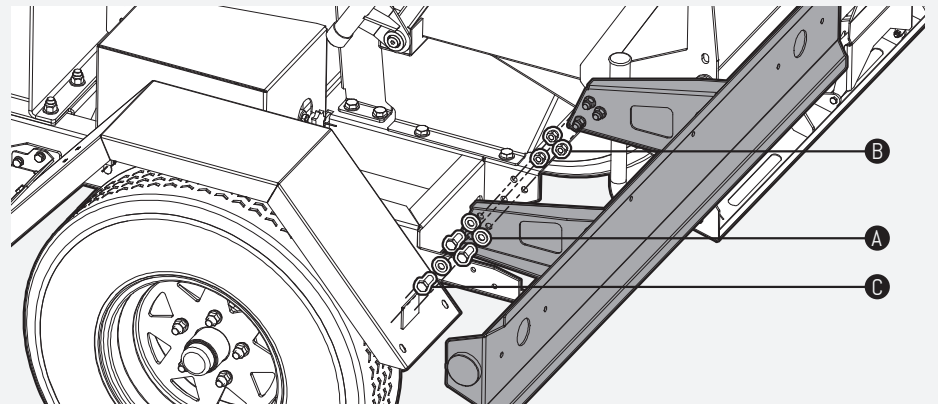
Use a full-thread M10×25 hexagon head bolt (C), Flat washer 10 (A), and an M10 hex lock nut (B) to assemble the taillight holder to the base frame.



A	Flat washer 10		x 6
B	Hex lock nut M10		x 6
C	Hex bolt M10 X 25mm		x 6