

DCH7 WOOD CHIPPER

2 YEARS
MACHINE WARRANTY

2 YEARS
ENGINE WARRANTY



Operator's Manual

MechMaxx

www.mechmaxx.com

INTRODUCTION

Congratulations on your purchase of the MechMaxx wood chipper!

This manual provides all the information you need to operate and maintain your machine safely and effectively. Read and understand the entire manual before use. If you have questions that are not addressed here, contact MechMaxx Customer Support for assistance.



Do not start or operate the machine before you read this manual. Make sure that you fully understand all the safety, operation, and maintenance information before you operate the machine.

Keep this manual with the machine at all times and available for frequent reference.

This machine is designed for specific applications only.

We strongly recommend not modifying or using it for any purpose other than its intended use. If you have questions about a specific application, DO NOT operate the machine until you contact us first to confirm it is suitable for that use.

For available accessories, go to mechmaxx.com.

ENGINE MANUAL

The engine manufacturer is responsible for all issues related to engine performance, power rating, specifications, warranty, and service. Consult the engine manufacturer's owner/operator manual for details.

MODEL AND SERIAL NUMBERS

Record the model and serial number as well as date and place of purchase for future reference. Have this information available when ordering parts or optional accessories and when making technical or warranty inquiries.

This manual is subject to change without notice. For the most current information, go to Mechmaxx.com.

TABLE OF CONTENTS

TABLE OF CONTENTS	1	ASSEMBLY	12
SPECIFICATIONS	2	KNOW YOUR MACHINE	14
SAFETY SIGNS	4	OPERATING INSTRUCTIONS	15
SAFETY	5	TRANSPORTATION	21
UNPACKING THE CONTAINER	9	MAINTENANCE	22
CONTENTS SUPPLIED	10	TROUBLESHOOTING	29
TO-SCALE HARDWARE	11		

SPECIFICATIONS

Model	DCH7	
Engine	HONDA GX690	ZONSEN GB750
Engine Type	Air Cooled 4-Stroke OHV Petrol Engine, 90°V-Twin Design, Horizontal Shaft	Dual Cylinder (90° V Type), 4 Stroke, Forced Air Cooling
Displacement	688 cc; 22 HP	750 cc; 25 HP
Rated Power	13.0 kW / 3600 RPM	15.5 kW / 3600 RPM
Max. Net Torque	48.3 N·m/2500 RPM	45 N·m / 2800 RPM
Fuel Capacity	3.17 gal	
Recommended Oil	SAE 10W-30 Classification SE or Higher	
Hydraulic Tank	6.87 gal	
Starting	Electric Starting	
Battery	36Ah 12V Lead-Acid Battery	
Ignition System	CDI	
Governor System	Mechanical Centrifugal Type	
Belt	2 x V-Belts	
Belts Material	Kevlar	
Clutch	Centrifugal Clutch	
Cutting Method	Disc	
Max. Chipping Dia.	7 in	
Feed Roller	7.5 in x 6.5 in	
Blade	2 x Blades; 1 x Anvil	2 x 8 in Blades; 2 x 6 in Anvil
Blade Material	A8 (5Cr8MoVSi)	
Blades Type	Double Edge Blade	
Flywheel System	Open Top Flywheel 26 in x1 in Twin	
Discharge Chute	360 Degree Rotating	
Emergency Stop	Stop Bar	
Towing Length	Tow Bar With 2 in Coupler	
Wheel	5.3-12 Tubeless	
Wheelbase	52.5 in	
Axle	Damping Torsion Axle	
Max. Speed	50 mph	

Chassis	Channel Steel Welded Frame
Package Method	Iron Fram With Black Film
Weight (N.W./G.W.)	1389/1587 lbs
Product Size (L*W*H)	137 x 55 x 90 in
Packing Size (L*W*H)	87 x 46 x 51 in
Machine Warranty	2 Years
Engine Warranty	2 Years

OVERALL DIMENSIONS

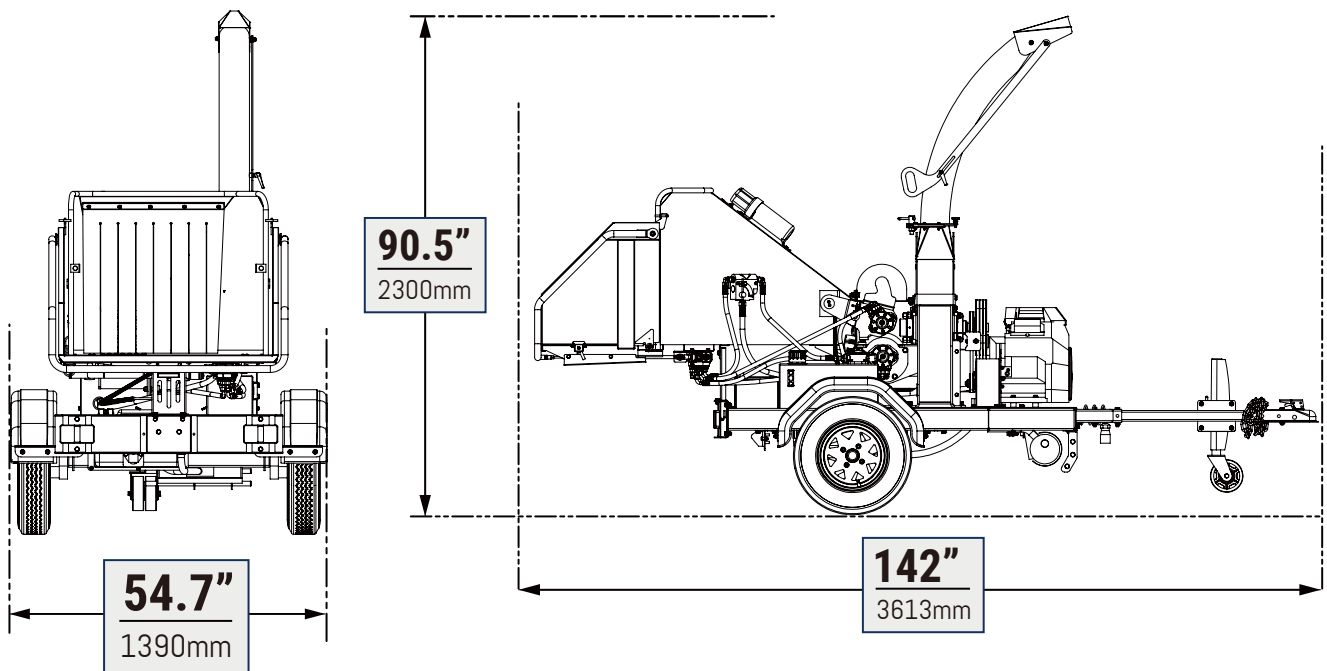

SAFETY SIGNS

The rating plate on your machine may show symbols. These represent important information about the product or instructions on its use.

⚠ WARNING ⚠

AVOID STANDING DIRECTLY IN FRONT OF FEED FUNNEL TO REDUCE EXPOSURE TO NOISE, DUST AND RISK FROM EJECTED PARTICLES.

DO NOT PUT ROAD SWEEPINGS IN MACHINE AS GRIT WILL DAMAGE BLADES.

⚠ WARNING ⚠

WHEN TRANSPORTING, DISCHARGE CLAMPS MAY WORK LOOSE. CHECK FREQUENTLY.

ALWAYS COVER IGNITION SWITCH WITH PLUG PROVIDED WHEN TOWING OR JET WASH CLEANING.

STOP

⚠ WARNING ⚠

DO NOT USE THIS MACHINE WITHOUT THE DISCHARGE UNIT FITTED. FAILURE TO COMPLY MAY RESULT IN SERIOUS INJURY OR DAMAGE.

ROTATING BLADES INSIDE. STOP ENGINE AND REMOVE KEY BEFORE REMOVING DISCHARGE UNIT.

⚠ WARNING ⚠

AUTO FEED SYSTEM FITTED. ROLLERS MAY TURN WITHOUT WARNING! WHEN THE ENGINE IS SWITCHED OFF THE ROLLERS WILL TURN DURING THE RUN DOWN PERIOD.

SAFETY

GENERAL SAFETY RULES

Read this manual and labels affixed to the machine to understand its limitations and potential hazards.

Be thoroughly familiar with the controls and their proper operation. Know how to stop the machine and disengage the controls quickly.

Make sure to read and understand all the instructions and safety precautions as outlined in the Engine Manufacturer's manual packed separately with your unit. Do not attempt to operate the machine until you fully understand how to properly operate and maintain the engine and how to avoid accidental injuries and/or property damage.

If the unit is to be used by someone other than original purchaser or loaned, rented, or sold, always provide this manual and any needed safety training before operation. The user can prevent and is responsible for accidents or injuries that may occur to themselves, other people, and property.

Do not force the machine. Use the correct machine for your application. The correct machine will do the job more efficiently and safer at the rate it was designed.

PERSONAL SAFETY

Do not permit children to operate this machine at any time.

Keep children, pets, and other people not using the unit away from the work area. Be alert and shut off unit if anyone enters work area. Keep children under the watchful care of a responsible adult.

Do not operate the machine while under the influence of drugs, alcohol, or any medication that could affect your ability to use it properly.

Dress properly. Wear heavy long pants, boots, and gloves. Do not wear loose clothing, short pants, or jewelry of any kind. Secure long hair so it is above shoulder level. Keep your hair, clothing, and gloves away from moving parts. Loose clothes, jewelry, or long hair can be caught in moving parts.

Protect eyes, face, and head from objects that may be thrown from the unit. Always wear safety goggles or safety glasses with side shields when operating.

Wear appropriate hearing protection.

Always keep hands and feet away from all moving parts during operation. Moving parts can cut or crush body parts.

Always keep hands and feet away from all pinch points.

Do not touch parts that might be hot from operation. Allow parts to cool before attempting to maintain, adjust, or service.

Stay alert, watch what you are doing, and use common sense when operating the machine.

Do not overreach. Do not operate the machine while barefoot or when wearing sandals or similar lightweight footwear. Wear protective footwear that will protect your feet and improve your footing on slippery surfaces. Keep proper footing and balance at all times. This enables better control of the machine in unexpected situations.

INSPECT YOUR MACHINE

Check your machine before starting it. Keep guards in place and in working order. Make sure all nuts, bolts, etc., are securely tightened.

Never operate the machine when it is in need of repair or is in poor mechanical condition. Replace damaged, missing, or failed parts before using it. Check for fuel leaks. Keep the machine in safe working condition.

Do not use the machine if the engine's switch does not turn it on or off. Any gasoline powered machine that can't be controlled with the engine switch is dangerous and must be replaced.

Regularly check to see that keys and adjusting wrenches are removed from the machine area before starting it. A wrench or a key that is left attached to a rotating part of the machine may result in personal injury.

Avoid accidental starting. Be sure the engine's switch is off before transporting the machine or performing any maintenance or service on the unit. Transporting or performing maintenance or service on a machine with its switch on invites accidents.

If the machine should start to vibrate abnormally, stop the engine and check immediately for the cause. Vibration is generally a warning sign of trouble.

ENGINE SAFETY

This machine is equipped with an internal combustion engine. Do not use on or near any unimproved, forest covered, or brush covered land unless the exhaust system is equipped with a spark arrester meeting applicable local, state, or federal laws.

Never start or run the engine inside a closed area. The exhaust fumes are dangerous, containing carbon monoxide, an odorless and deadly gas. Operate this unit only in a well-ventilated outdoor area.

Do not tamper with the engine to run it at excessive speeds. The maximum engine speed is preset by the manufacturer and is within safety limits. See engine manual.

Keep a Class B fire extinguisher on hand when operating this Wood chipper in dry areas as a precautionary measure.

FUEL SAFETY

Fuel is highly flammable, and its vapors can explode if ignited. Take precautions when using to reduce the chance of serious personal injury.

When refilling or draining the fuel tank, use an approved fuel storage container while in a clean, well-ventilated outdoor area. Do not smoke, or allow sparks, open flames, or other sources of ignition near the area while adding fuel or operating the unit. Never fill the fuel tank indoors.

Keep grounded conductive objects, such as tools, away from exposed, live electrical parts and connections to avoid sparking or arcing. These events could ignite fumes or vapors.

Always stop the engine and allow it to cool before filling the fuel tank. Never remove the cap of the fuel tank or add fuel while the engine is running or when the engine is hot. Do not operate the machine with known leaks in the fuel system.

Loosen the fuel tank cap slowly to relieve any pressure in the tank.

Never overfill the fuel tank. Fill the tank to no more than 1/2" below the bottom of the filler neck to provide space for expansion as the heat of the engine can cause fuel to expand.

Replace all fuel tank and container caps securely and wipe up spilled fuel. Never operate the unit without the fuel cap securely in place.

Avoid creating a source of ignition for spilled fuel. If fuel is spilled, do not attempt to start the engine but move the machine away from the area of spillage and avoid creating any source of ignition until fuel vapors have dissipated.

When fuel is spilled on yourself or your clothes, wash your skin and change clothes immediately.

Store fuel in containers specifically designed and approved for this purpose.

Store fuel in a cool, well-ventilated area, safely away from sparks, open flames, or other sources of ignition.

Never store fuel or a machine with fuel in the tank inside a building where fumes may reach a spark, open flame, or any other source of ignition, such as a water heater, furnace, or clothes dryer. Allow the engine to cool before storing in any enclosure.

SPECIFIC SAFETY RULES

Identify hazards and take preventive steps to avoid accidents and minimize risk. Possible hazards include, but are not limited to, moving parts, thrown objects, weight of the machine and components, and the operating environment.

PRIOR TO STARTING

Thoroughly inspect the area in which you are working, keeping it clean and free of debris to prevent tripping. Operate on a flat level ground.

Before starting your chipper shredder: make sure the feed hopper and cutting housing are empty and free of all debris, check the oil level, make sure all nuts and bolts are tight, and check the air pressure in the tires.

OPERATION SAFETY

Never place any part of your body where it would be in danger if movement should occur during assembly, installation, operation, maintenance, repair, or moving.

Keep all bystanders and pets at least 75 feet away. If you are approached, stop the unit immediately.

Never place your hands, feet, or any part of your body in the chipper hopper, discharge opening, or near or under any moving part while the machine is running. Keep the area of discharge clear of people, animals, buildings, glass, or anything else that will obstruct clear discharge, causing injury or damage. Wind can also change discharge direction, so be aware. If it becomes necessary to push materials to the chipper hopper, use a small-diameter stick, not your hands.

Keep your face and body back from the chipper hopper and discharge chute to avoid injury from accidental bounce back of material.

Never reach with your hands inside the feed hopper past the rubber flap while operating the machine.

Keep combustible substances away from the engine when it is hot.

Do not tilt the machine while the engine is running

Never operate this machine without the feed hopper or discharge chute properly attached.

FEEDING MATERIALS

Feed only clean materials into the machine. Foreign matter such as soil, sand, grit, stones, pieces of metal, etc. will damage the sharp edge of the cutting knives. Root balls and dead wood will also dull the blades quickly

Avoid feeding pine needles, flax and cabbage tree leaves into the machine; these stringy materials can wrap around the rotor shaft and work their way into the bearing.

Avoid feeding short, stubby pieces of wood into the machine; they tend to bounce and spin in the feed hopper. Feed these short pieces together with longer pieces. After becoming familiar with the machine, prune to suit its capabilities.

This machine is self-feeding, do not force branches into the blades. Allow the machine to automatically feed through. Allow time for the machine to reach the highest spinning revolutions before feeding the next load of branches.

GENERAL SAFETY MATTERS

- Always stop the chipper engine before making any adjustments, refuelling or cleaning.
- Always check the rotor has stopped rotating and remove the chipper ignition key before maintenance of any kind, or whenever the machine is to be left unattended. If in doubt, look through the in-feed funnel to see if rotor is still moving.
- Always check the machine is well supported and cannot move. If working on an incline, position on solid ground, across the slope.
- Always operate the chipper with the engine set to maximum speed when chipping.
- Always check (visually) for fluid leaks. If found, resolve the leak before operating the chipper.

- Always take regular breaks. Wearing personal protective equipment for long periods can be tiring and hot.
- Always keep hands, feet and clothing out of feed opening, discharge and moving parts.
- Always use a push stick to push in short pieces. Under no circumstances should you reach into the funnel.
- Always keep the operating area clear of people, animals and children.
- Always keep the operating area clear from debris build up.
- Always keep clear of the chip discharge tube. Foreign objects may be ejected with great force.
- Always ensure protective guarding is in place before commencing work. Failure to do so may result in personal injury or loss of life.
- Always operate the chipper in a well ventilated area - exhaust fumes are dangerous.
- Ensure a fire extinguisher is available on site.
- Ensure a personal first aid kit and hand cleaning materials are available (e.g. waterless skin cleanser).
- Always cover ignition switch with plug provided when towing or jet wash cleaning.

UNCLOGGING

Never allow processed material to build up in the discharge area. This can prevent proper discharge and result in kickback from the chipper hopper.

Never attempt to unclog either the feed hopper or discharge chute while the engine is running. Immediately shut off the engine, allow the cutting disk to come to a complete stop, and then remove the clogged material. Inspect for damage and check for any loose parts for repair or replacement.

Whenever you leave the operating position or if you have to remove processed material, leaves, or debris from the machine, always shut down the engine, and ensure the engine is switched to "off" to prevent accidental starting, and wait for all moving parts to come to a complete stop.

Before opening the cutting disk housing, always make sure the engine is switched off, the cutting disk is at a complete standstill, and the belt drive is disengaged.

MOVING

Move the machine at least 10 feet away from the refueling point before starting engine.

This chipper shredder is for movement by hand only. Never attempt to tow the machine on public highways, roads, or thoroughfares.

Always stop the engine before moving the machine, and watch out for sharp objects that could pierce the tires.

MACHINE USE AND CARE

Position the machine in such a way that it can not move during maintenance, cleaning, adjustment, assembly of accessories or spare parts, as well as under storage

Do not force the machine. Use the correct machine for your application. The correct machine will do the job better and safer at the rate for which it is designed.

Do not change the engine governor settings or over-speed the engine. The governor controls the maximum safe operating speed of the engine.

Do not run the engine at a high speed when you are not working.

Do not put hands or feet near rotating parts.

This machine has two rotating cutting knives capable of amputating hands and feet and throwing objects. Keep hands and feet out of openings while machine is running. Failure to observe these safety instructions could result in serious injury or death.

Avoid contact with hot fuel, oil, exhaust fumes and hot surfaces. Do not touch the engine or muffler. These parts get extremely hot from operation. They remain hot for a short time after you turn off the unit. Allow the engine to cool before doing maintenance or making adjustments.

If the machine should start to make an unusual noise or vibration, immediately shut off the engine, disconnect the spark plug wire, and check for the cause. Unusual noise or vibration is generally a warning of trouble.

Use only attachments and accessories approved by the manufacturer. Failure to do so can result in personal injury.

Keep the engine and muffler free of grass, leaves, excessive grease or carbon build up to reduce the chance of a fire hazard.

Never douse or squirt the unit with water or any other liquid. Keep handles dry, clean and free from debris. Clean after each use.

Observe proper disposal laws and regulations for gas, oil, etc. to protect the environment.

When storing machine out of the reach of children and do not allow persons unfamiliar with the machine or these instructions to operate it. This machine can be dangerous when used by an untrained user.

MAINTAINING YOUR MACHINE

Some parts of this machine are made of plastic or rubber and should be kept away from chemicals.

Never cover the machine while the muffler is still hot.

Do not alter or adjust any part of the chipper shredder or its engine that is sealed by the manufacturer or distributor. Only a qualified service technician may adjust parts that increase or decrease governed engine speed.

To maintain your machine, check for any misalignment or binding of any moving parts. Parts that are broken or worn down that may affect the machine's operation. If damage or worn parts are identified, they should be repaired before use. Many accidents are caused by poorly maintained equipment.

BASIC WOODCHIPPING SAFETY

The operator should be aware of the following points:

- Maintain a safety exclusion zone around the chipper of at least 10 metres for the general public or employees without adequate protection. Use hazard tape to identify this working area and keep it clear from debris build up. Chips should be ejected away from any area the general public have access to.
- Hazardous material - Some species of trees and bushes are poisonous. The chipping action can produce vapour, spray and dust that can irritate the skin. This may lead to respiratory problems or even cause serious poisoning. Check the material to be chipped before you start. Avoid confined spaces and use a face mask if necessary.
- Be aware when the chipper is processing material that is an awkward shape. The material can move from side to side in the funnel with great force. If the material extends beyond the funnel, the brush may push you to one side causing danger. Badly twisted brush should be trimmed before being chipped to avoid thrashing in the feed funnel.
- Be aware that the chipper can eject chips out of the feed funnel with considerable force. Always wear full head and face protection.
- Always work on the side of the machine furthest from any local danger, e.g. not road side.
- Never leave the chipper unattended when running. Machines must be supervised at all times when in use.
- In the event of an accident, stop the machine, remove the key and call the emergency services immediately.

UNPACKING THE CONTAINER

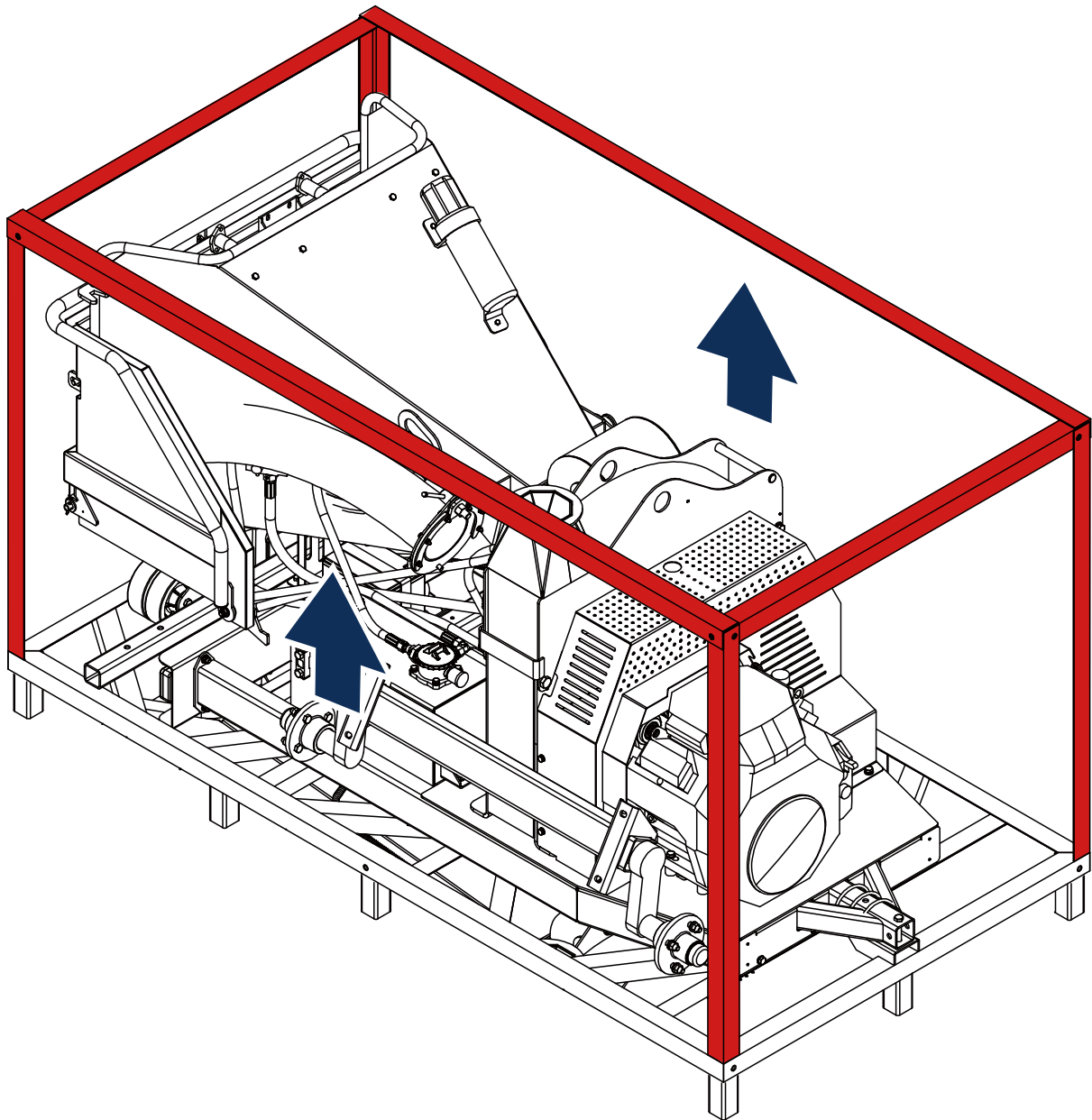

Remove the packaging frame of the machine using a tool.

CONTENTS SUPPLIED

Your Wood chipper comes partially assembled and contains the following:

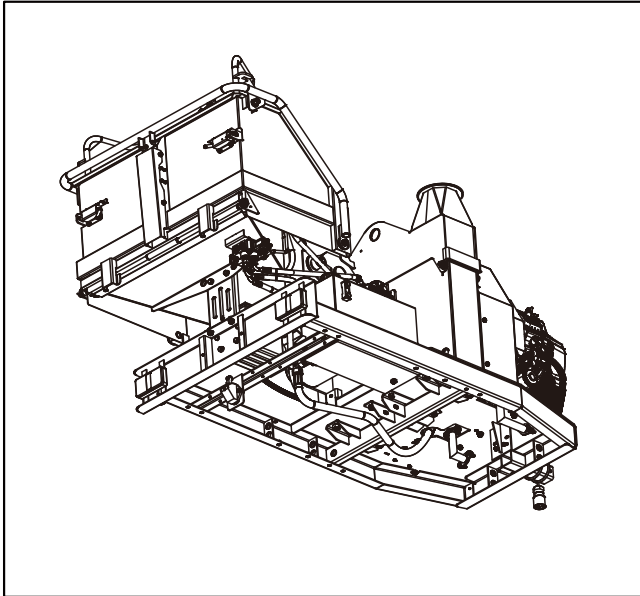

1x Engine and base frame

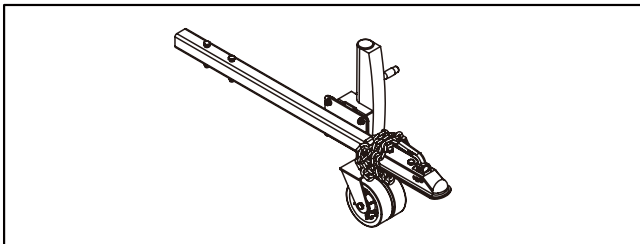

1x Tow bar

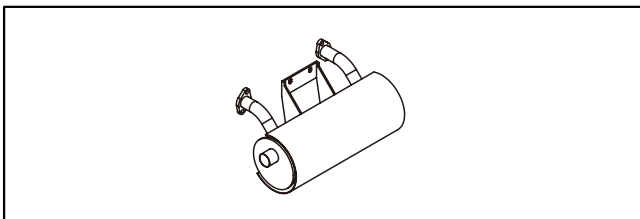

1x Muffler

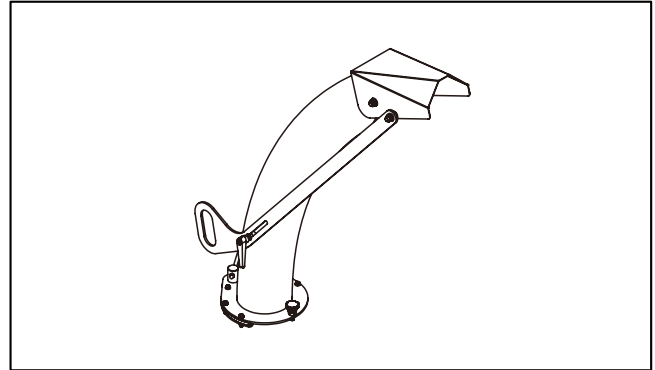

1x Expulsion Chute

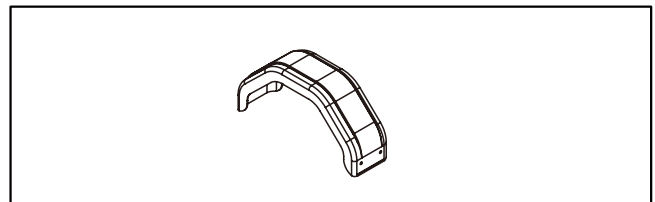

1x Mudguard

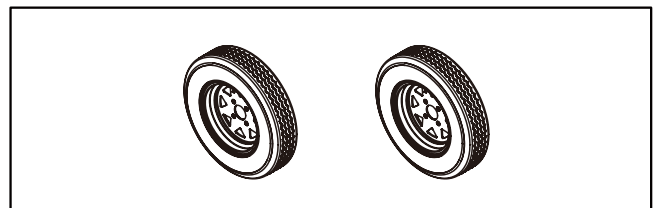

1x Wheels

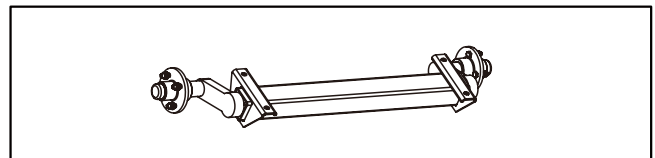

1x Axle

Verify all component and hardware quantities are correct prior to assembling the Wood chipper.

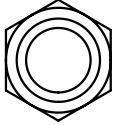
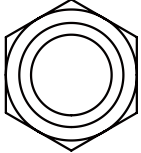
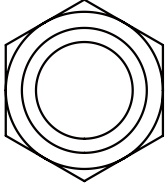

TO-SCALE HARDWARE

Hardware graphics are printed at 1:1 scale for ease of identification. Simply place the hardware over the image in the tables to verify it is the correct size.

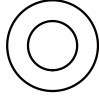
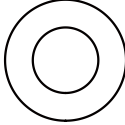
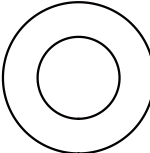
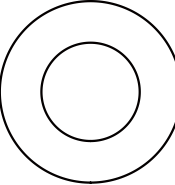
<p>Hex lock nut M6 8X</p>	
<p>Hex lock nut M8 12X</p>	
<p>Hex lock nut M10 4X</p>	
<p>Hex lock nut M12 2X</p>	

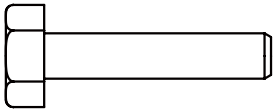
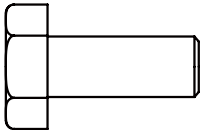
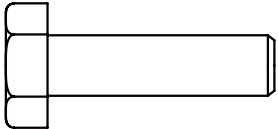
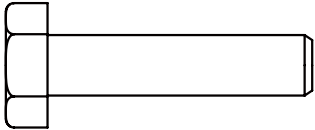
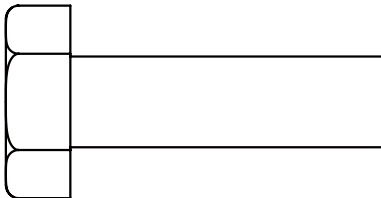
<p>Flat washer 6 8X</p>	
<p>Flat washer 8 14X</p>	
<p>Flat washer 10 6X</p>	
<p>Flat washer 12 4X</p>	

<p>Hex bolt M6 X 30mm 8X</p>	
<p>Hex bolt M8 X 20mm 2X</p>	
<p>Hex bolt M8 X 30mm 4X</p>	
<p>Hex bolt M8 X 35mm 2X</p>	
<p>Hex bolt M12 X 30mm 2X</p>	

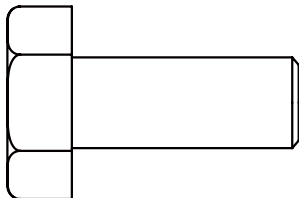
<p>Spring washer 6 8X</p>	
<p>Hex bolt M10 X 25mm 6X</p>	
<p>Hex bolt M12 X 30mm 4X</p>	

ASSEMBLY

AXLE

Attach the torsion axle to the chassis using a flat washer (12), hex bolt (M12x30), and spring washer (12).

Attach the wheel to the torsion axle using a flange spherical nut. (See Figure 1)

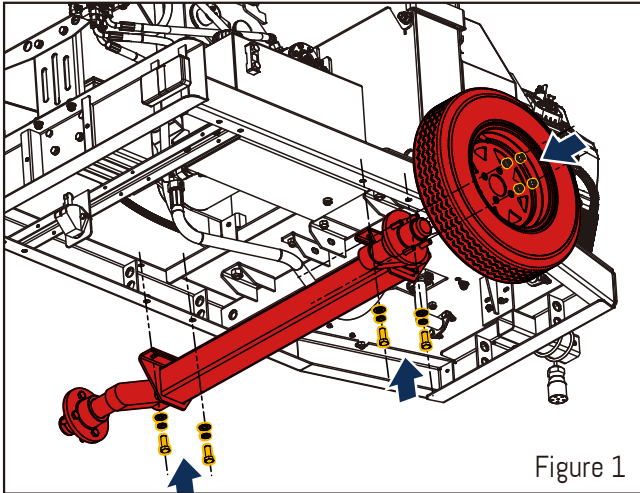
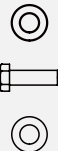

Figure 1

- 4X Spring washer 12
- 4X Hex bolt M12 X 30mm
- 4X Flat washer 12



TOW BAR

Attach the tow bar to the chassis using a hex bolt (M12x80), flat washer (12), and lock nut (M12). (See Figure 2)

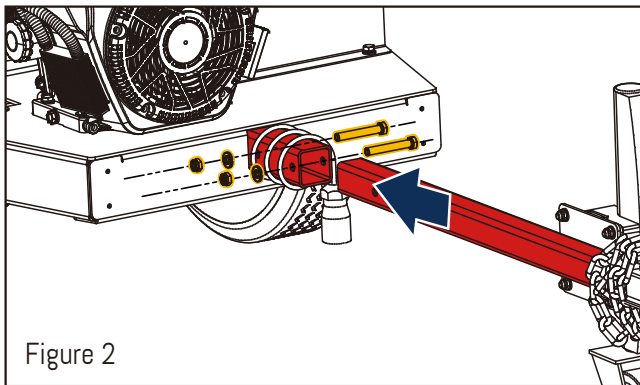
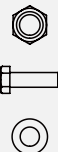

Figure 2

- 2X Hex lock nut M12
- 2X Hex bolt M12 X 80mm
- 2X Flat washer 12



MUFFLER

Attach the muffler gasket to the middle of exhaust pipe 2, exhaust pipe 1, and the muffler.

Attach the muffler to exhaust pipe 2 and exhaust pipe 1 using a hex bolt (M8x30), flat washer (8), spring washer, and hex nut (M8).

Attach the muffler to the chassis using a hex bolt (M8x20), flat washer (8), spring washer (8), and hex nut (M8). (See Figure 3)

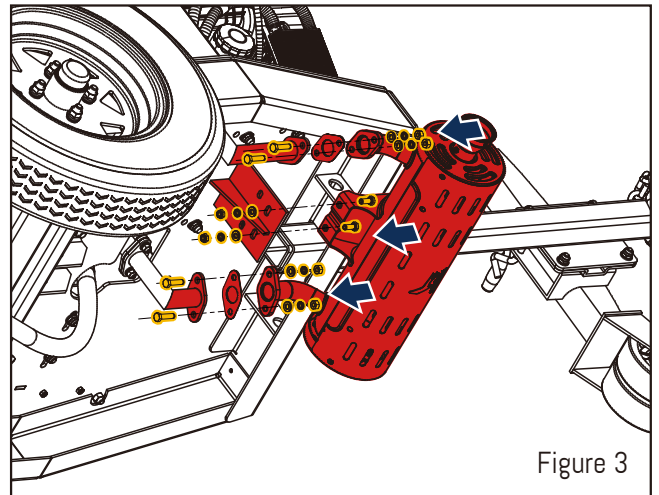

Figure 3

- 6X Spring washer 8
- 2X Hex bolt M8 X 20mm
- 6X Flat washer 8
- 6X Hex lock nut M8
- 4X Hex bolt M8 X 30mm



FUEL TANK

Attach the fuel tank rack to the torsion axle using a U-bolt, flat washer (8), and lock nut (M8).

Attach the fuel tank to the fuel tank rack.

Attach the fuel tank fixing plate to the fuel tank.

Attach the lower end of the fuel tank fixing plate to the fuel tank rack using a hex bolt (M8x35), flat washer, and lock nut (M8).

Attach the upper end of the fuel tank fixing plate to the chassis using a hex bolt (M8x35), flat washer (8), and lock nut (M8). (See Figure 4)

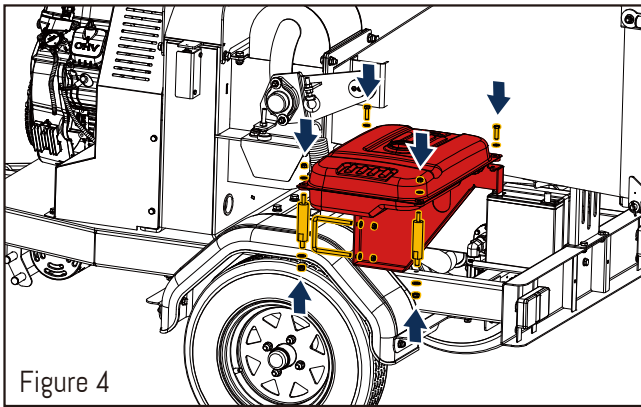

Figure 4

- 2X Hex bolt M8 X 35mm
- 8X Flat washer 8
- 8X Hex lock nut M8

MUDGUARD

Attach mudguard bracket 1 and mudguard bracket 2 to the chassis using M10x25 bolts, spring washer (10), and flat washer (10).

Attach the mudguard to mudguard bracket 1 and mudguard bracket 2 using M10x25 bolts, flat washer (10), and lock nut (M10). (See Figure 5)

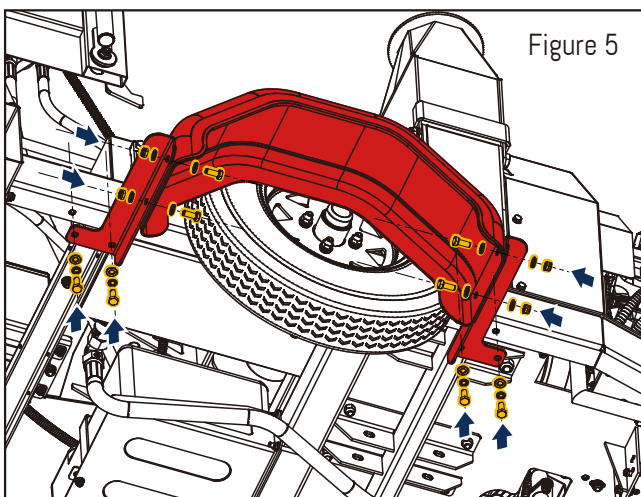

Figure 5

- 6X Spring washer 10
- 6X Hex bolt M10 X 25mm
- 6X Flat washer 10
- 4X Hex lock nut M10

LOWER EXPULSION CHUTE

Place the compression plate, rotating gasket, and discharge chute on the rotor cover in order, and attach them using M6x30 bolts, flat washer (6), and lock nut (M6).

Place the clamp and flange plate at the notch of the rotating gasket, then attach them to the discharge chute using the handle shaft.

Attach the lever to the handle shaft and mount the hex nut (M6) on both ends of the lever. (See Figure 6)

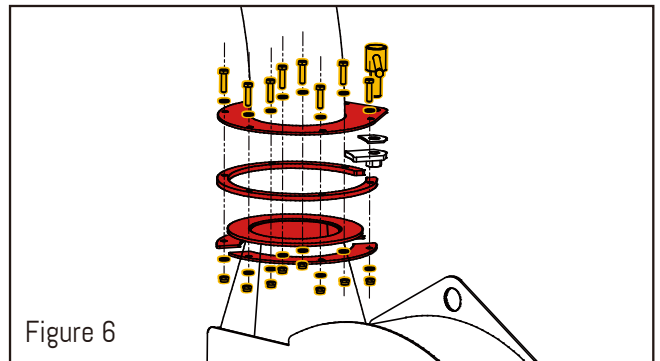
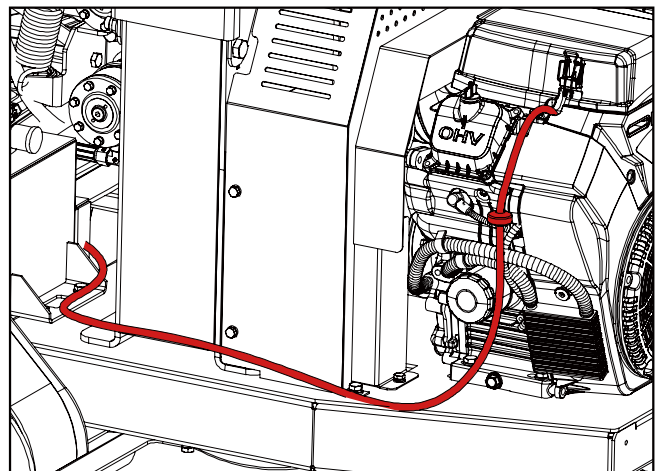

Figure 6

- 8X Spring washer 6
- 8X Hex bolt M6 X 30mm
- 8X Flat washer 6
- 8X Hex lock nut M6

CONNECT THE OIL PIPE TO THE ENGINE.



KNOW YOUR MACHINE

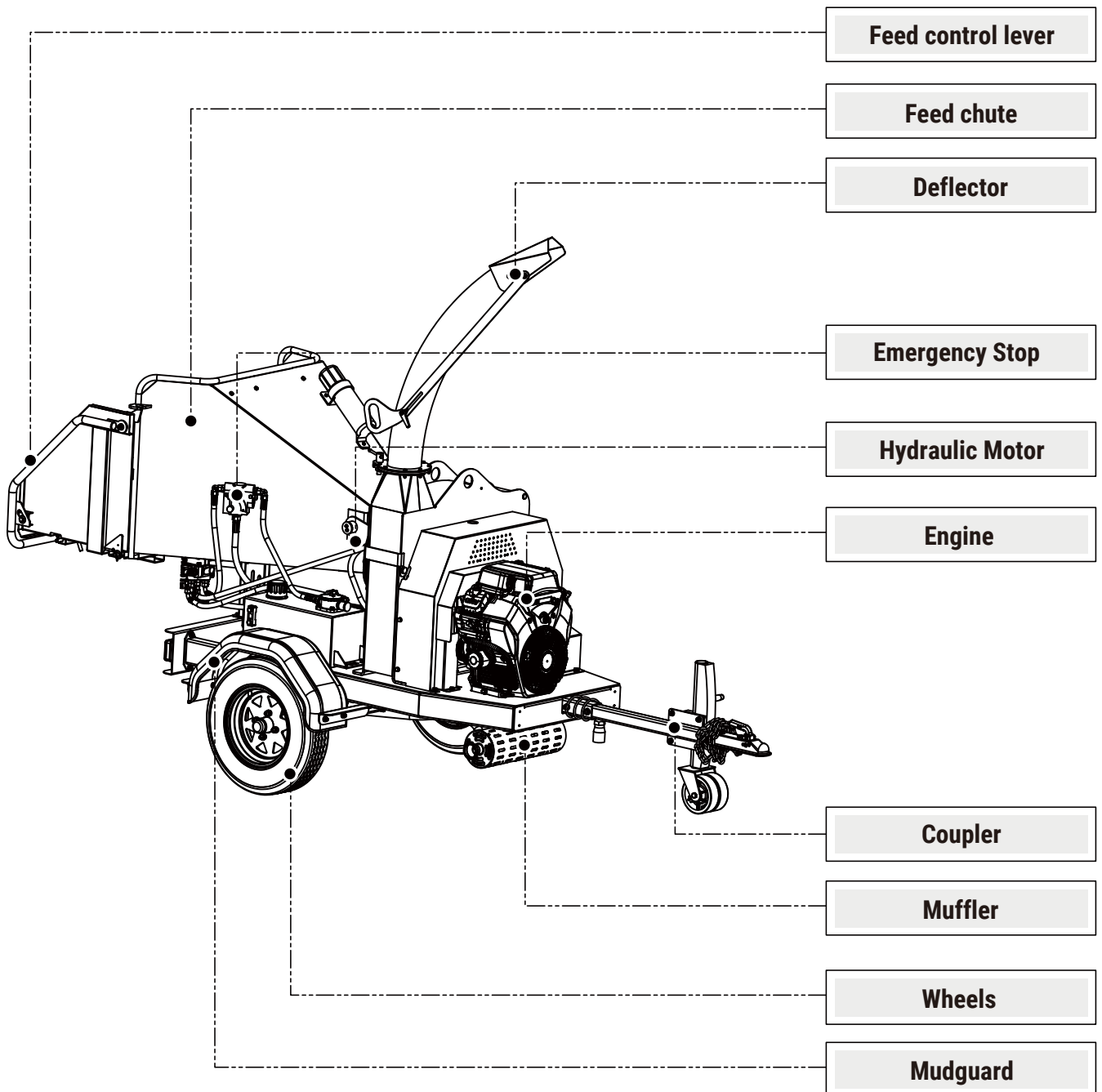

OPERATING INSTRUCTIONS



The engine is shipped without oil. Do not start the engine before adding oil.

ADD OIL TO ENGINE

1. Make sure the chipper shredder is on a flat, level surface.
2. Remove the oil fill cap / dipstick to add oil.

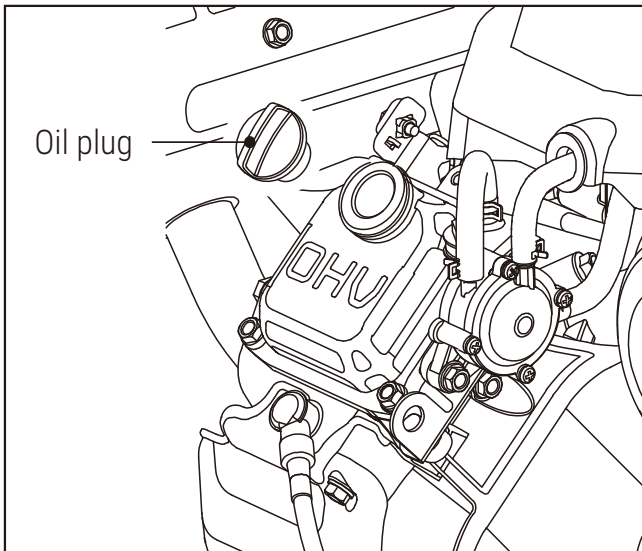

3. Using a funnel, add oil up to the FULL mark on the dipstick.



DO NOT OVERFILL. Check engine oil level daily and add as needed.



Gasoline is highly flammable and explosive. You can be burned or seriously injured when handling fuel. Use extreme care when handling gasoline.



Fill the fuel tank outdoors, never indoors. Gasoline vapors can ignite if they collect inside an enclosure. Explosion can result.

4. Reinstall the fuel cap and tighten. Always clean up spilled fuel.

STARTING ENGINE

1. If the fuel tank is equipped with a valve, be sure the fuel valve is in the OPEN or ON position before attempting to start the engine.
2. To start a cold engine, pull the choke knob out to the CLOSED position.

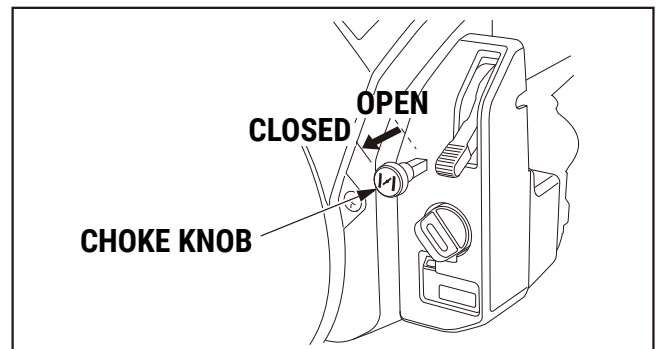

To restart a warm engine, leave the choke knob in the OPEN position.

3. Move the throttle lever away from the MIN. position, about 1/3 of the way toward the MAX. position.

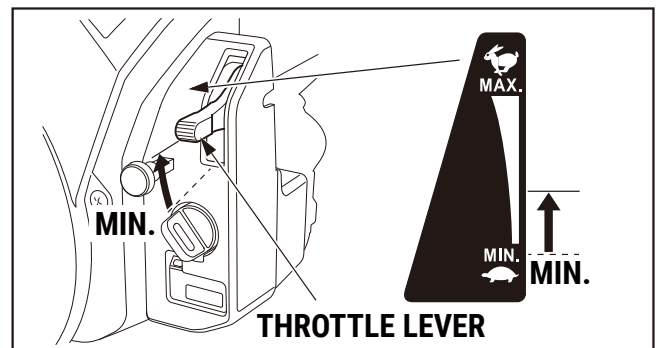

4. Turn the engine switch to the ON position.

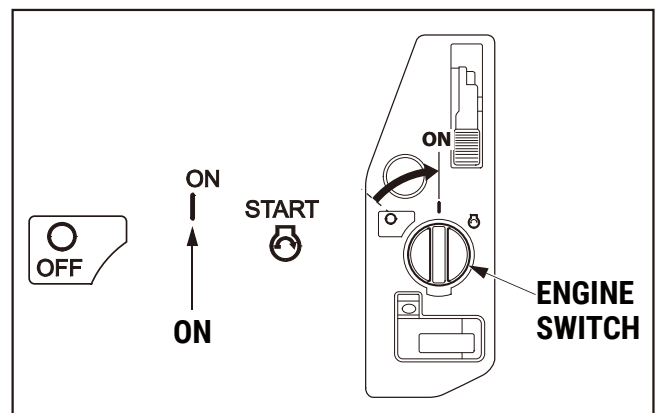

5. Press and hold the starter button.

Turn the engine switch to the START position, and hold it there until the engine starts. If the engine fails to start within 5 seconds release the engine switch, and wait at least 10 seconds before operating the starter again.

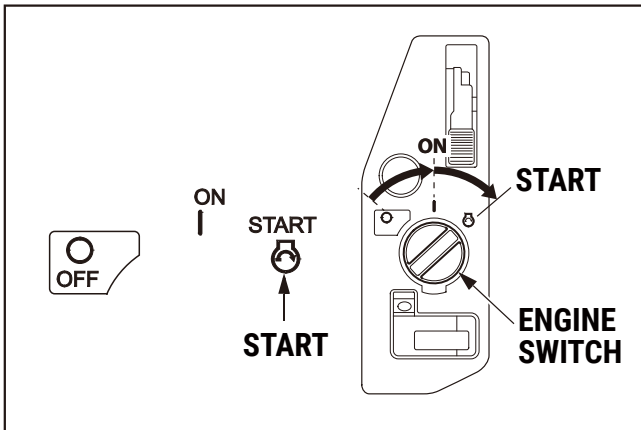

Using the electric starter for more than 5 seconds at a time will overheat the starter motor and can damage it. When the engine starts, release the engine switch, allowing it to return to the ON position.

6. Warm up the engine for 2 or 3 minutes.

7. If the choke knob was pulled to the CLOSED position to start the engine, gradually push it to the OPEN position as the engine warms up.

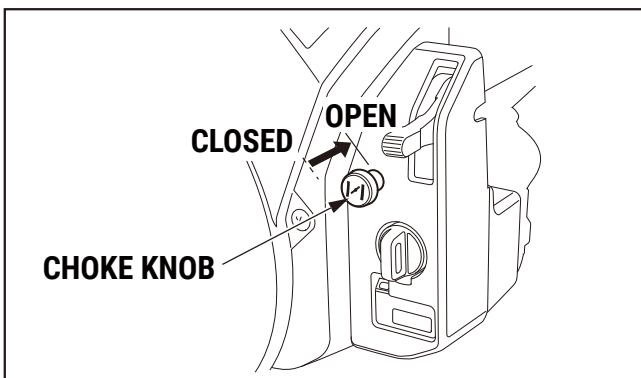

STOPPING THE ENGINE

To stop the engine in an emergency, simply turn the engine switch to the OFF position. Under normal conditions, use the following procedure. Refer to the instructions provided by the equipment manufacturer.

1. Move the throttle lever to the MIN. position. Some engine applications use a remote-mounted throttle control rather than the engine-mounted throttle lever shown here.

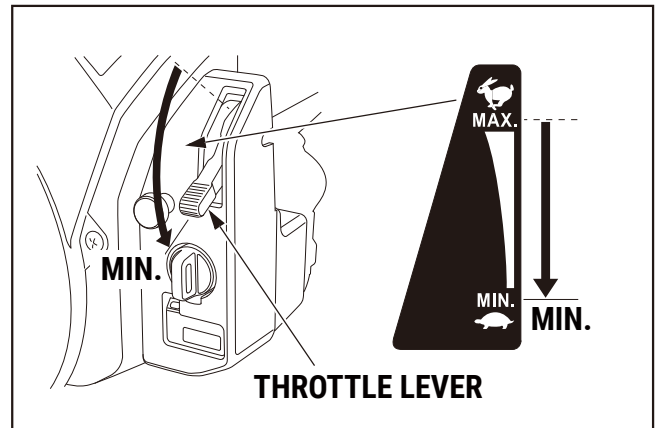

2. Turn the engine switch to the OFF position.

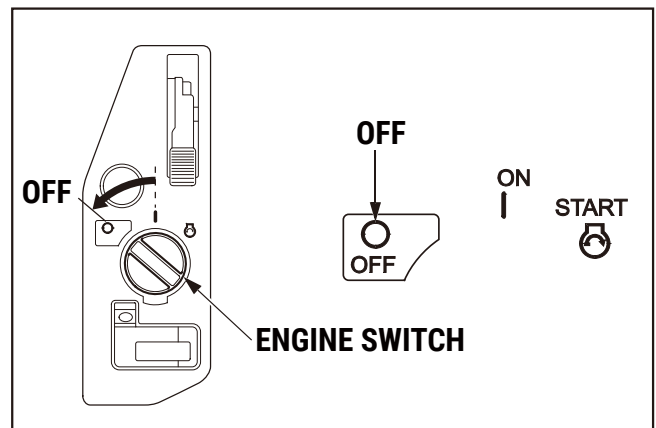

3. If the fuel tank is equipped with a valve, turn the fuel valve to the CLOSED or OFF position.

If different, please go to mechmaxx.com and search for the machine you purchased and refer to the engine manual.

OPERATING

After the engine warms up, pull the throttle lever to accelerate engine speed.

The chipper shredder can process a wide variety of dry or green organic materials such as branches, stalks, vines, leaves, roots, and vegetable matter. The maximum capacity is 7-inch diameter branches, this can vary depending on the type and hardness of wood. Rotating the branch as you feed it into the machine will improve performance.

The wood chipper can clog up with soft, wet, or fibrous materials. However, if you feed soft materials intermittently with branches, there should be no problem, as the wood chipper tends to clean out any residue left in the machine.

If any stringy material wraps around the rotor shaft, remove it before it works its way into the bearing.

OPERATOR'S PERSONAL PROTECTIVE EQUIPMENT REQUIRED

- Chainsaw safety helmet fitted with visor and recommended ear defenders to an appropriate specification.
- Heavy-duty gloves with elasticated wrist area.
- Keep in mind that the operator or user is responsible for accidents or hazards occurring to other people, their property, and themselves.
- Avoid wearing loose clothing or jewelry, which can catch on moving parts.
- Keep bystanders at least 50 feet (15m) away from your work area at all times. Stop the engine when another person or pet approaches.
- Close - fitting heavy-duty non-sag clothing.
- Safety footwear.
- Facemask (if appropriate).

MANUAL CONTROLS

Roller control boxes- a control box is located on either side of the feed funnel. Their function is to control the feed roller whilst processing material. They do not control the main rotor.

RED SAFETY BAR = This is the large red bar that surrounds the feed tray and side of the feed funnel. The bar is spring loaded and connected to a switch that will interrupt the power to the rollers. The switch is designed so that it only activates if the bar is pushed to the limit of its travel.

HYDRAULIC MOTOR RATATION AND STOP

Two hydraulic motors are fixed on the feeding roller and rotate in opposite directions to roll the wood into the chipping house.

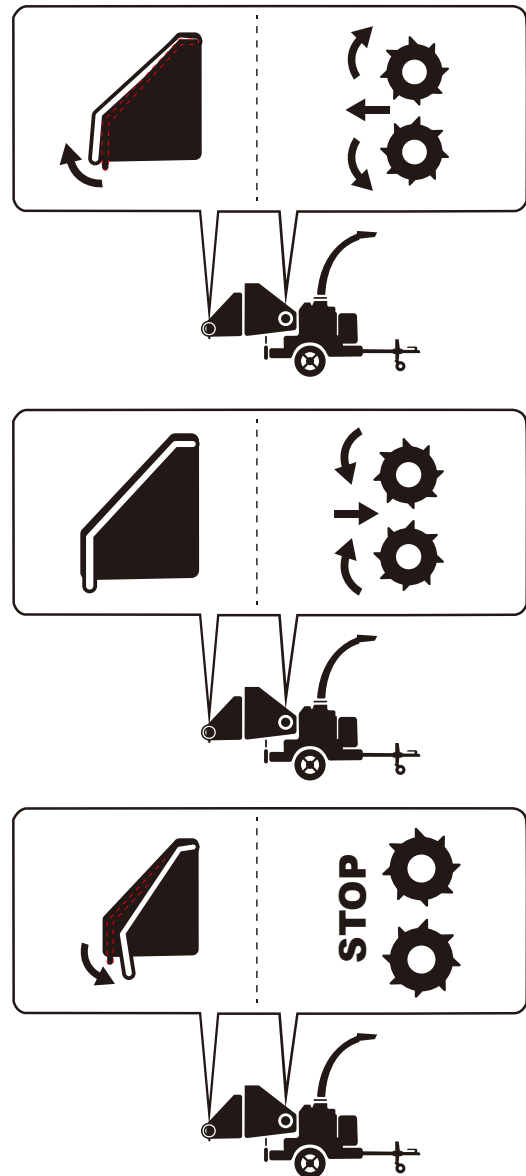

FEEDING SPEED ADJUSTMENT

Flow control valve controls the motor rotation speed. When breaking branches with large diameter, the flow rate can be appropriately lowered, and the speed can be adjusted up when the branches are small.

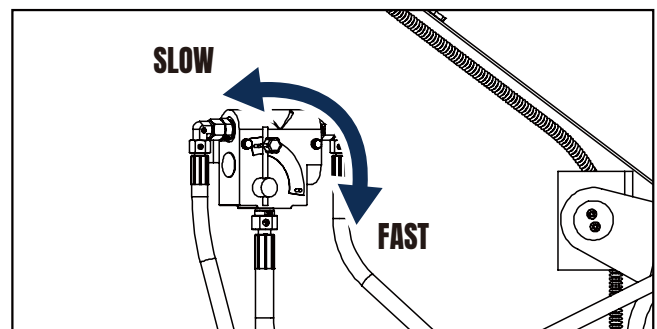

STOPPING THE ROLLERS & ENGINE

Pushing the red Emergency stop button positioned on top of the funnel kills all power to both the engine and the rollers, bringing the machine to a complete stop. It overrides all buttons and bars and will not allow the chipper to function until it has been reset. To reset, pull out button until it returns to its original position, turn the ignition key back to the off position, before restarting the machine.

ENGINE CONTROLS

This label indicates the speed setting of the chipper. With the throttle lever in the fast position (hare) the machine is ready to chip. When the machine is not in use for short periods of time move the lever to the idle position (tortoise) or turn off completely. Move the lever to idle position and turn off the choke, the engine will be stopped.

BLADE WEAR

The most important part of using a wood chipper is keeping the cutter blades sharp. chipper blades are hollow ground to an angle of 40 degrees. When performing daily blade checks ensure blade edge is sharp and free from chips, if there is any evidence of damage, or the edge is "dull" change the blade(s). The wood chipper is fitted with 2 blades 8 in long. They are 8 in wide when new. A new blade should chip for up to 25 hours before it requires sharpening. This figure will be drastically reduced by feeding the machine with stony, sandy or muddy material.

As the blade becomes blunt, performance is reduced. With increased stress and load on the machine the chips will become more irregular and stringy. At this point the blade should be sent to a reputable blade sharpening company. The blade can be sharpened several times in its life. A wear mark indicates the safe limit of blade wear. Replace when this line is exceeded.

The machine is also fitted with a static blade (anvil). It is important that the anvil is in good condition to allow the cutting blades to function efficiently. Performance will be poor even with sharp cutter blades if the anvil is worn.

PETROL TANK INDICATOR

The fuel level may be inspected by removing the fuel filler cap and looking into the tank.

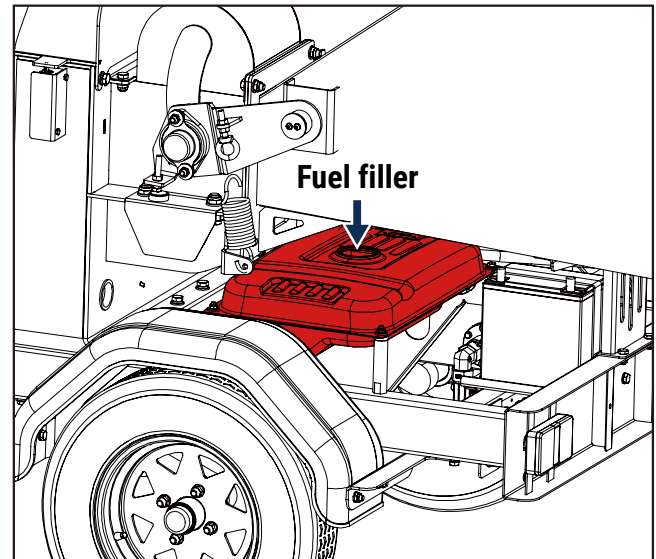

DAILY CHECKS BEFORE STARTING

- Locate the machine on firm level ground.
- Check machine is well supported and cannot move.
- Check jack stand is lowered and secure.
- Check all guards are fitted and secure.
- Check the discharge unit is in place and fastened securely.
- Check discharge tube is pointing in a safe direction.
- Check the feed funnel to ensure no objects are inside.
- Check feed tray is in up position - to prevent people reaching rollers.
- Check controls as described below.
- Check (visually) for fluid leaks.
- Check fuel and hydraulic oil levels.

BEFORE USING THE CHIPPER

It is essential to carry out the following tests to check safety equipment - this sequence of tests will only take a few seconds to carry out. We recommend that these tests are carried out daily. Observing the function as described will confirm that the safety circuits are working correctly. This is also a good opportunity to remind all operators of the control and emergency stop systems.

- Start the engine, test if the feed roller and its hydraulic system can operate normally.
- To ensure the safety bar is always operational it must be activated once before each work session. The rollers will not function until the bar is activated. This procedure must be repeated each time the ignition is switched off.
- Check the emergency stop button as well

STARTING THE ENGINE

FOR A COLD ENGINE:

- Place the throttle control at 1/3 throttle and pull the choke out.
- Insert ignition key into starter switch.
- Turn the key to start the engine. Release the key as soon as the engine starts.
- Gradually return the choke to the off position as the engine starts and warms up. Allow the engine to warm up for at least one minute before chipping.

FOR A WARM ENGINE:

Follow the instructions for a 'cold engine' but return the choke to the off position as soon as the engine starts.

If engine fails to start after 10 seconds leave for 1 minute and try again.

STOPPING THE ENGINE

- Set engine to idle position.
- Allow to run for at least one full minute.
- Switch off and remove ignition key.

For more detailed information refer to the Engine Owner's Manual

STARTING TO CHIP



DO NOT USE OR ATTEMPT TO START THE CHIPPER WITHOUT THE PROTECTIVE GUARDING AND DISCHARGE UNIT SECURELY IN PLACE. FAILURE TO DO SO MAY RESULT IN PERSONAL INJURY OR LOSS OF LIFE.

- Check that the chipper is running smoothly.
- Release the catches on the feed tray and lower.
- Stand to one side of the feed funnel.
- Proceed to feed material into the feed funnel.

Wood up to the recommended diameter can be fed into the feed funnel. Put the butt end in first and engage it with the feed rollers. The hydraulic feed rollers will pull the branch into the machine quite quickly. Large diameter material will have its feed rate automatically controlled by the no stress unit.

Sometimes a piece of wood that is a particularly awkward shape is too strong for the feed rollers to break. This will cause the top roller to either bounce up and down on the wood, or both rollers to stall. Pull the material out of the feed funnel and trim it so the chipper can handle it.

Both feed rollers should always turn at the same speed. If one or both rollers stop or suddenly slow down it may be that a piece of wood has become stuck behind one of the rollers. If this occurs, adjust hydraulic directional control valve to 'reverse feed' position, the rollers will turn reverse and roll out the stuck wood, then you can adjust the hydraulic directional control valve to "forward feed" position, the chipper will work again. If this operation doesn't work, pls push the EMERGENCY STOP BUTTON, turn the engine off, remove the ignition key and investigate.

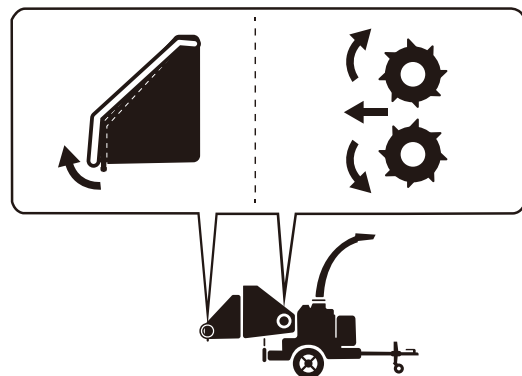

BLOCKAGES

Always be aware that what you are putting into the chipper must come out. If the chips stop coming out of the discharge tube but the chipper is taking material in - STOP IMMEDIATELY.

Continuing to feed material into a blocked machine may cause damage and will make it difficult to clear.

If the chipper becomes blocked, proceed as follows:

- Stop the engine and remove the ignition keys.
- Remove the discharge tube. Check that it is clear.
- Wearing gloves, reach into the rotor housing and scoop out the majority of the debris causing the blockage.



DO NOT REACH INTO THE ROTOR HOUSING WITH UNPROTECTED HANDS. THERE ARE SHARP BLADES AND ANY SMALL MOVEMENT OF THE ROTOR MAY CAUSE SERIOUS INJURY.

- Replace the discharge tube.
- Restart the engine and increase to full speed.
- Allow machine time to clear excess chips still remaining in rotor housing before you continue feeding brushwood. Feed in a small piece of wood while watching to make sure that it comes out of the discharge. If this does not clear it, repeat the process and carefully inspect the discharge tube to find any obstruction.

NOTE: Continuing to feed the chipper with brushwood once it has become blocked will cause the chipper to compact the chips in the rotor housing and it will be difficult and time consuming to clear.

DISCHARGE CONTROLS ROTATION

Controlling the discharge is an essential part of safe working.

- Slacken nut using integral handle 1.
- Rotate to desired angle using handle 2.
- Retighten nut

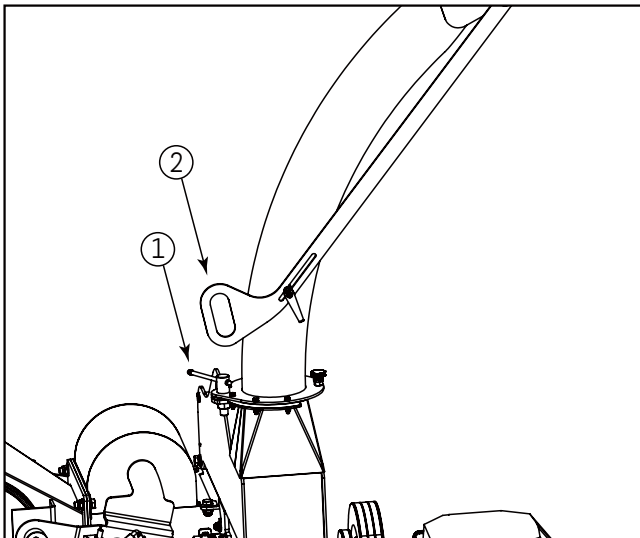

TRANSPORTATION

SAFE TRANSPORTATION

- On rough or bumpy road surfaces reduce speed accordingly to protect your machine from unnecessary vibration.
- When towing off road be aware of objects that may catch the chipper undergear.
- When towing off road ensure inclination is not excessive.
- Avoid excessively pot holed ground.
- When reversing the chipper the short wheel base will react quickly to steering.



DO NOT RIDE ON THE CHIPPER WHEN IT IS BEING TOWED.

- Always check the discharge is tight before moving.
- Keep tyre pressures inflated to 2.2 bar or 32 psi.
- Check wheel nuts are tightened to 90nm or 65 lbs ft.
- Clear loose chippings and debris from the machine before departing.
- Ensure feed funnel is closed and the catch is properly engaged before departing.

HITCHING ONTO THE TOW BALL

- Check ball head is well greased.
- Wind jockey wheel assembly anticlockwise until the tow head is above the height of the ball hitch on the vehicle.
- Reverse vehicle so the ball hitch is directly below the tow head.
- Attach breakaway cable to a strong point on the vehicle, not the ball hitch.
- Grasp handle on tow head and push back catch with thumb.
- Wind jockey wheel assembly clockwise, to lower the tow head onto the ball hitch.
- Release handle and continue to wind jockey wheel clockwise. The tow head should snap into place on the ball hitch. If it doesn't, repeat previous 2 steps.
- Wind jockey wheel up until fully retracted and the jockey wheel frame is seated in its notch on the stem. The chipper weight should be fully on the vehicle.
- Release jockey wheel clamp and slide the jockey wheel assembly fully up.
- Tighten clamp on jockey wheel assembly.

- Connect electrical plug to socket on rear of towing vehicle and check operation of all the trailer and vehicle lights.
- Check the engine ignition switch is covered with the plug provided.
- The chipper is now properly attached to the vehicle.

UNHITCHING THE CHIPPER

- Ensure the chipper will not roll away after being disconnected from the vehicle. Use the chocks provided if in doubt.
- Disconnect the electrical cable from the vehicle socket.
- Release breakaway cable.
- Release the jockey wheel assembly clamp.
- Lower the jockey wheel assembly fully.
- Retighten the jockey wheel assembly clamp.
- Wind the jockey wheel assembly anticlockwise until it starts to take the weight of the chipper.
- Grasp the handle and release the catch with your thumb.
- Continue to wind the jockey wheel anticlockwise. This should lift the tow head clear of the ball hitch.
- Drive the vehicle clear of the chipper.
- Wind the jockey wheel assembly to a suitable point where the chipper is level.
- The chipper is now fully detached from the vehicle.

STABILISING THE CHIPPER

When hitched to a vehicle the prop stand and jockey wheel should be stored in the towing position (a)

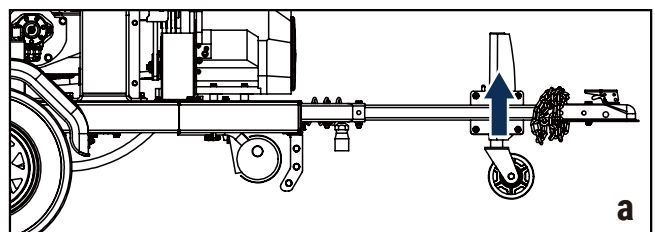

When the chipper is unhitched it should be secured before starting work by using the wheel chocks and lowering the prop stand and jockey wheel (b).

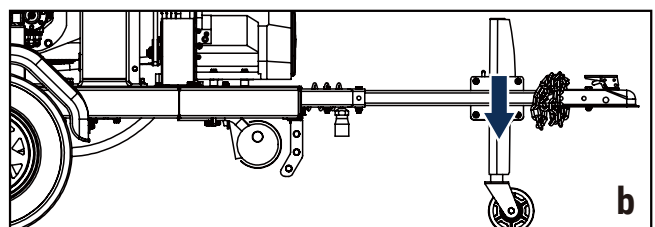

MAINTENANCE



ALWAYS IMMOBILISE THE MACHINE BY STOPPING THE ENGINE, REMOVING THE IGNITION KEY AND DISCONNECTING THE BATTERY BEFORE UNDERTAKING ANY MAINTENANCE WORK.

Procedure	Daily Check	50 Hours	100 Hours	500 Hours	1 Year
Check engine oil - top up if necessary (10W-30).	▲				
Check for engine oil / hydraulic oil leaks.	▲				
Check fuel level.	▲				
Check feed funnel, feed roller cover, access covers, engine covers and discharge unit are securely fitted.	▲				
Check blades	▲				
Ensure engine air intake is free from leaf build up.	▲				
Check tyre pressure is 2.2 Bar (32 psi).	▲				
Check safety bar mechanism.	▲				
Grease the roller box slides.	▲	OR AS REQUIRED - SEE PAGE 20			
Grease the roller spline and bearing.	▲				
Clean air filter element.	DEPENDING ON WORKING ENVIRONMENT				
Check for tightness all nuts, bolts and fastenings making sure nothing has worked loose.		▲			
Grease discharge flange.		▲			
Check tension of main drive belts.		▲			
Check anvils for wear.		▲			
Check fuel pipes and clamp bands.			▲		
Check battery electrolyte level.			▲		
Check for loose electrical wiring.			▲		
Replace hydraulic oil filter every year or 100 hours after service or repair work to the hydraulic system.			▲	OR	▲
Replace hydraulic oil.			▲	OR	▲
Replace fuel pipes and clamp bands.	REFER TO YOUR ENGINE SUPPLIERS MANUAL				
Check spark plugs.					

Procedure	Daily Check	50 hours	100 hours	500 hours	1 Year
Change engine oil.	REFER TO YOUR ENGINE SUPPLIERS MANUAL				
Replace engine oil filter cartridge.					
Check valve clearance.					
Replace anvils when worn.	RETURN TO DEALER FOR ANVIL CHANGE				
Axle maintenance.	REFER TO SUPPLIERS INSTRUCTION SHEET				
Tow head maintenance.					

NOTE: Your woodchipper is covered by a full 24 months parts and labour warranty. Subject to correct maintenance and proper machine usage, the bearings are guaranteed for 24 months regardless of hours worked by the machine. In conditions of 'heavy usage' - i.e. in excess of 500 hours per year - it is recommended that the bearings are changed annually to ensure that the machine retains optimum working performance.

SAFE MAINTENANCE

ALWAYS IMMOBILISE THE ENGINE BEFORE UNDERTAKING ANY MAINTENANCE WORK ON THE CHIPPER BY REMOVING THE KEY AND DISCONNECTING THE BATTERY.

- Handle blades with extreme caution to avoid injury.- Gloves should always be worn when handling the cutter blades.
- THE drive belts should be connected while changing blades, as this will restrict sudden movement of the rotor.
- The major components of this machine are heavy.Lifting equipment must be used for disassembly.
- CLEAN machines are safer and easier to service.
- Avoid contact with hydraulic oil.

SAFE LIFTING OF THE CHIPPER

The lifting eye is designed to lift the machine's weight only. Do not use hoist hook directly on the lifting eye, use a correctly rated safety shackle. Inspect the lifting eye prior to each use - DO NOT USE LIFTING EYE IF DAMAGED.

SPARES

Only fit genuine replacement blades, screws and chipper spares. Failure to do so will result in the invalidation of the warranty and may result in damage to the chipper, personal injury or even loss of life.

BATTERY REMOVAL AND MAINTENANCE

- Remove the negative lead first and then the positive lead.
- Clean, charge and/or top up the battery as required.
- Refitting is the reverse of removal. Apply a smear of petroleum jelly to the terminals to prevent corrosion.

CHECK FITTINGS

The HYDRAULIC WOOD CHIPPER is subject to large vibrations during the normal course of operation. Consequently there is always a possibility that nuts and bolts will work themselves loose. It is important that periodic checks are made to ensure the security of all fasteners. Fasteners should be tightened using a torque wrench to the required torque (see below). Uncalibrated torque wrenches can be inaccurate by as much as 25%. It is therefore essential that a calibrated torque wrench is used to achieve the tightening torques listed below.

	Size	Head	Torque lb ft	Torque Nm
Blade Bolts	M16	24mm Hex	90	125
Anvil Bolts	M10	8 mm Allen Key	65	88
General	M8	13 mm Hex	20	27
General	M10	17 mm Hex	45	61
General	M12	19 mm Hex	65	88

The blade bolts need to have thread glue applied to them.

BATTERY SAFETY INFORMATION

WARNING NOTES AND SAFETY REGULATIONS FOR FILLED LEAD-ACID BATTERIES



For safety reasons, wear eye protection when handling a battery.



Keep out of reach of children.



- Fires, sparks, naked flames and smoking are prohibited.
- Avoid causing sparks when dealing with cables and electrical equipment, and beware of electrostatic discharges.
- Avoid short circuits.

EXPLOSION HAZARD



A highly explosive oxyhydrogen gas mixture is produced when batteries are charged.

CORROSIVE HAZARD



Battery acid is highly corrosive, therefore:

- Wear protective gloves and eye protection.
- Do not tilt the battery, acid may escape from the vent openings.

FIRST AID

Rinse acid splashes in the eyes immediately for several minutes with clear water. Remove contact lenses if worn and continue rinsing. Then, consult a doctor immediately.



Neutralize acid splashes on the skin or clothing immediately with acid neutralizer (soda) or soap suds, and rinse with plenty of water.

If acid is swallowed, consult a doctor immediately.

WARNING NOTES: THE BATTERY CASE CAN BECOME BRITTLE, TO AVOID THIS:



- Do not store batteries in direct sunlight.
- Discharged batteries may freeze up, therefore store in an area free from frost.

FIRST AID



- Dispose of old batteries at an authorised collection point.
- The notes listed under item 1 are to be followed for transport.
- Never dispose of old batteries in household waste.

STORAGE AND TRANSPORT

- Batteries are filled with acid.
- Always store and transport batteries upright and prevent from tilting so that no acid can escape.
- Store in a cool and dry place.
- Do not remove the protective cap from the positive terminal.
- Run a FIFO (first in-first out) warehouse management system.

INITIAL OPERATION

- The batteries are filled with acid at a density of 1.28g/ml during the manufacturing process and are ready for use.
- Recharge in case of insufficient starting power

INSTALLATION IN THE VEHICLE AND REMOVAL FROM THE VEHICLE

- Switch off the engine and all electrical equipment.
- When removing, disconnect the negative terminal first.
- Avoid short circuits caused by tools, for example.
- Remove any foreign body from the battery tray, and clamp battery tightly after installation.
- Clean the terminals and clamps, and lubricate slightly with battery grease. When installing, first connect the positive terminal, and check the terminal clamps for tight fit.
- After having fitted the battery in the vehicle, remove the protective cap from the positive terminal, and place it on the terminal of the replaced battery in order to prevent short circuits and possible sparks.
- Use parts from the replaced battery, such as the terminal covers, elbows, vent pipe connection and terminal holders (where applicable); use available or supplied filler caps.
- Leave at least one vent open, otherwise there is a danger of explosion. This also applies when old batteries are returned.

CHARGING

- Remove the battery from the vehicle; disconnect the lead of the negative terminal first.
- Ensure good ventilation.
- Use suitable direct current chargers only.
- Connect the positive terminal of the battery to the positive output of the charger. Connect the negative terminal accordingly.

- Switch on the charger only after the battery has been connected, and switch off the charger first after charging has been completed.
- Charging current-recommendation: 1/10 ampere of the battery capacity Ah.
- Use a charger with a constant charging voltage of 14.4V for re-charging.
- If the acid temperature rises above 55° Celsius, stop charging.
- The battery is fully charged when the charging voltage has stopped rising for two hours.

MAINTENANCE

- Keep the battery clean and dry.
- Use a moist anti-static cloth only to wipe the battery, otherwise there is a danger of explosion.
- Do not open the battery.
- Recharge in case of insufficient starting power

JUMP STARTING

- Use the standardised jumper cable in compliance with DIN 72553 only, and follow the operating instructions.
- Use batteries of the same nominal voltage only.
- Switch off the engines of both vehicles.
- First connect the two positive terminals (1) and (2), then connect the negative terminal of the charged battery (3) to a metal part (4) of the vehicle requiring assistance away from the battery.
- Start the engine of the vehicle providing assistance, then start the engine of the vehicle requiring assistance for a maximum of 15 seconds.
- Disconnect the cables in reverse sequence (4-3-2-1).

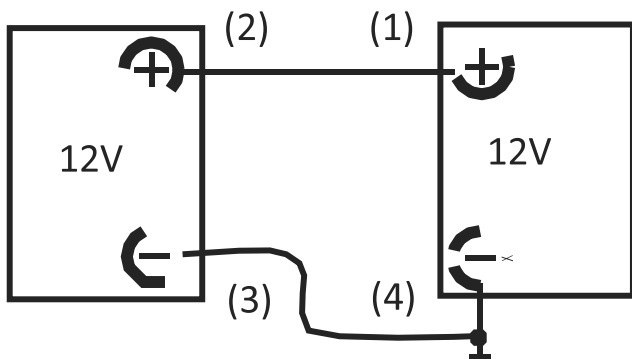

TAKING THE BATTERY OUT OF SERVICE

- Charge the battery; store in a cool place or in the vehicle with the negative terminal disconnected.
- Check the battery state of charge at regular intervals, and correct by recharging when necessary

CHANGE BLADES



WEAR RIGGERS GLOVES FOR THE BLADE CHANGING OPERATION.

1. Turn the chipper off and remove the ignition keys.
2. Remove battery leads.
3. Remove the M10 bolt retaining the guard, allowing the guard to be opened.

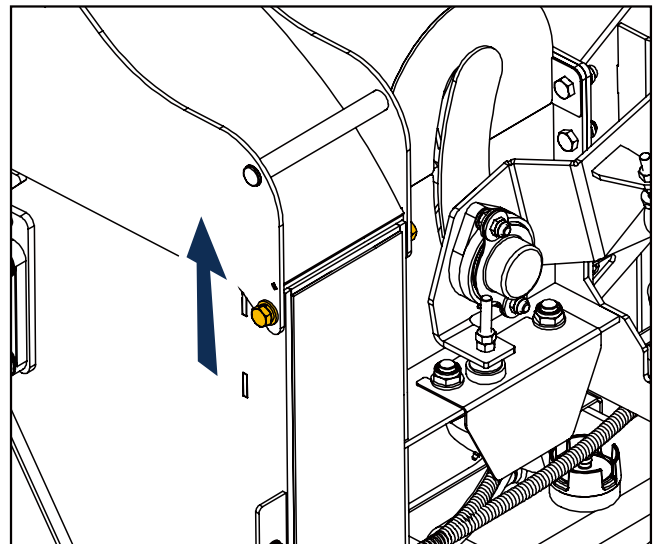

5. Turn rotor to blade change position.
6. Insert locking bar into rotor housing and rotor. Must ensure that the opening time must longer than the time when the moving parts stop. Before opening the housing cover, pls see through the transparent cover to see if the roller stopped.
7. Brush away all dirt and debris from the rotor and blades.
8. With a 1inch spanner/socket undo the two nyloc nuts and washers that are holding the blade in place. Remove both blade bolts from the blade.

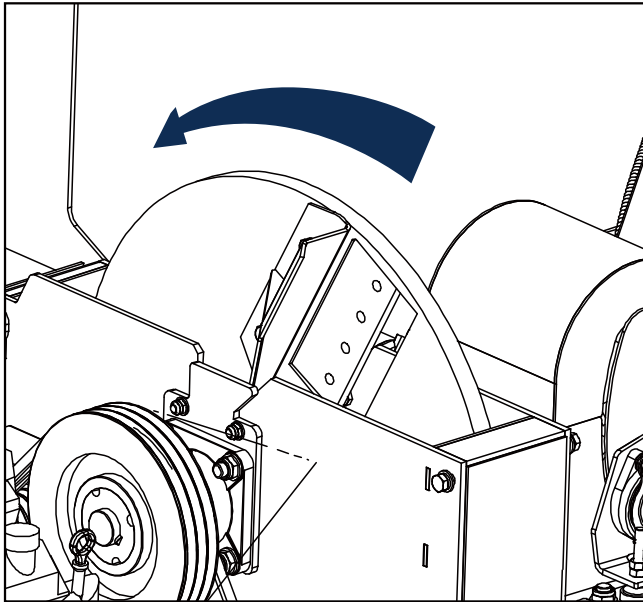

10. Withdraw the blade from the rotor.

11. Clean the back surface of the blade, blade bolts and blade area of the rotor before reseating blades. The blades must not have any material underneath them when tightened. If they are not flat and tight they will become loose very quickly.

12. Reassemble the blades, bolts, washers and nuts in the order shown in the diagram above. Use only genuine nuts and washers, as they are of a higher grade than normally stocked at fastener factories. Failure to use the appropriate grade nuts or washers may result in damage, injury or death. The use of genuine blades and bolts is recommended.

13. Apply a smear of anti seize compound (copper ease) to the bolt threads and back face of the nuts. Do not apply copper grease onto the counter bore faces of the blades or bolts.

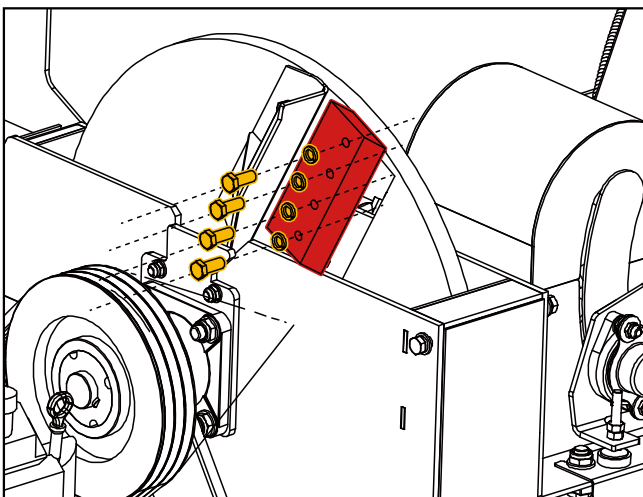

ALWAYS SHARPEN BLADES ON A REGULAR BASIS. FAILURE TO DO SO WILL CAUSE THE MACHINE TO UNDER PERFORM AND WILL OVERLOAD ENGINE AND BEARINGS CAUSING MACHINE BREAKDOWN. BLADES MUST NOT BE SHARPENED BEYOND THE WEAR MARK (SEE DIAGRAM). FAILURE TO COMPLY WITH THIS COULD RESULT IN MACHINE DAMAGE, INJURY OR LOSS OF LIFE.

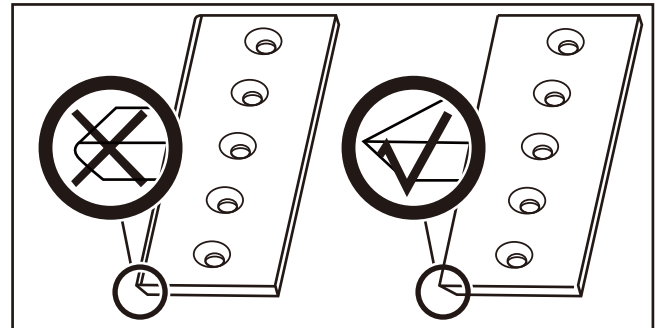
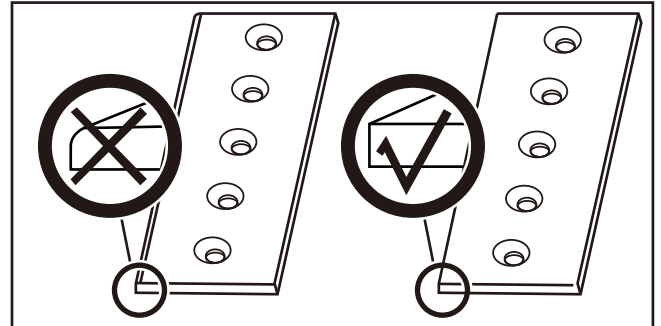

TENSION BELTS

NOTE: There will normally be a rapid drop in tension during run-in period for new belts. When new belts are fitted, check the tension every 2 - 3 hours and adjust until the tension remains constant.

TENSION DRIVE BELTS

1. Remove belt guard.
2. Loosen bolt in centre of tensioner pulley with a 0.74 inch spanner so that pulley is able to slide with minimal wobble.
3. Turn nut in end of tensioner pulley slider until correct belt tension is achieved. For instructions on checking belt tension & correct belt tension values, please refer to the V-Belt Tensioning Data Table.
4. Retighten bolt in centre of tensioner pulley.
5. Refit belt guard.
6. Run machine and test, recheck belt tension.

NOTE: Slack drive belts will cause poor performance and excess belt and pulley wear.

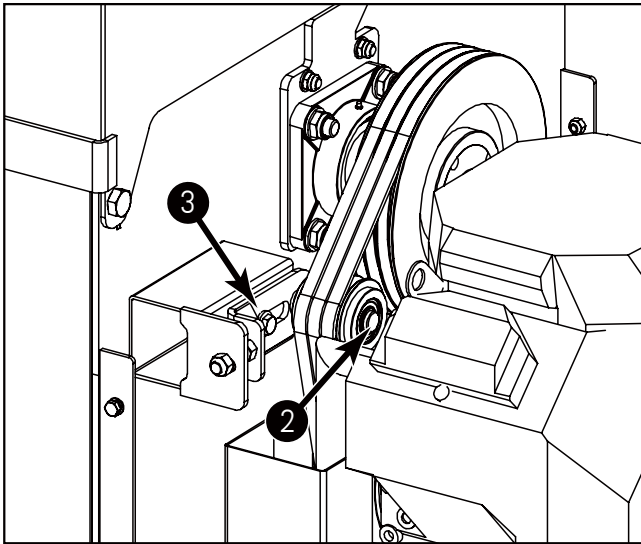

TENSION HYDRAULIC PUMP BELT

1. Remove belt guard.
2. Access the two nuts on the under side of the chassis and slacken using a 0.74 inch socket spanner.
3. Adjust the M8 bolt on the outside plate until the desired tension is achieved. For instructions on checking belt tension & correct belt tension values, please refer to the V-Belt Tensioning Data Table .
4. Retighten the two nuts to (88 Nm) 65 lbs/ft.
5. Refit belt guard.

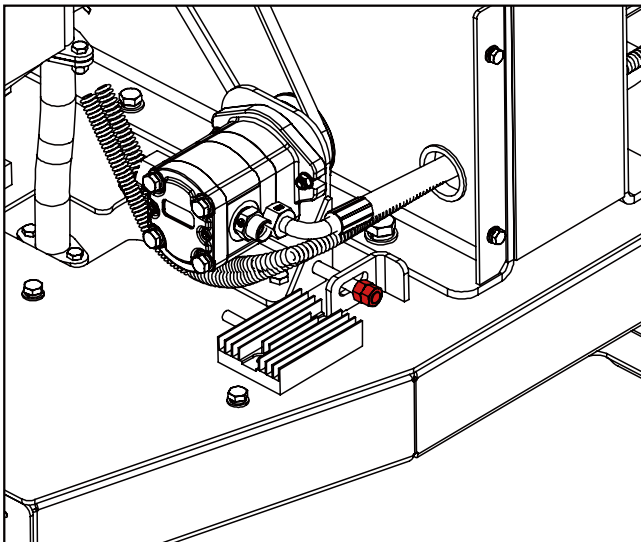

CHANGE HYDRAULIC OIL AND FILTER



USE PLASTIC GLOVES TO KEEP OIL OFF SKIN AND DISPOSE OF THE USED OIL AND FILTERIN AN ECOLOGICALLY SOUND WAY. THE OIL AND FILTER SHOULD BE CHANGED ONCE AYEAR OR AT ANY TIME IT BECOMES CONTAMINATED. BEFORE STARTING CHECK THATTHE CHIPPER IS STANDING LEVEL AND BRUSH AWAY LOOSE CHIPS.

1. Remove the black screw cap from the top of the filter housing.
2. Partially remove filter element from inner cup. Leave filter to drain for 15 minutes.
3. Remove filter element from cup when clear of hydraulic oil.
4. Remove drain plug and drain oil into a suitable container.
5. Replace drain plug.
6. Refill with ISO VG 46 hydraulic oil until the level is between the min and max lines on the tank (about 15 litres).
7. Refit the filter cup, install a new filter element and refit the black screw cap, to the filter housing, ensuring o-ring remains in place.

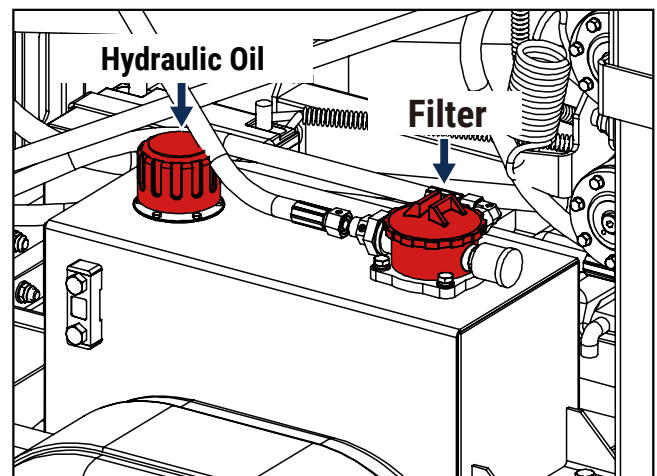

REFUELING

Recommended Fuel

This engine is certified to operate on unleaded gasoline with a pump octane rating of 86 or higher (a research octane rating of 91 or higher). Refuel in a well ventilated area with the engine stopped. If the engine has been running, allow it to cool first. Never refuel the engine inside a building where gasoline fumes may reach flames or sparks. You may use unleaded gasoline containing no more than 10% ethanol (E10) or 5% methanol by volume. In addition, methanol must contain cosolvents and corrosion inhibitors. Use of fuels with content of ethanol or methanol greater than shown above may cause starting and/or performance problems. It may also damage metal, rubber, and plastic parts of the fuel system. Engine damage or performance problems that result from using a fuel with percentages of ethanol or methanol greater than shown above are not covered under the Warranty.

RECOMMENDED OIL

Use 4-stroke motor oil that meets or exceeds the requirements for API service category SJ or later (or equivalent). Always check the API service label on the oil container to be sure it includes the letters SJ or later (or equivalent).

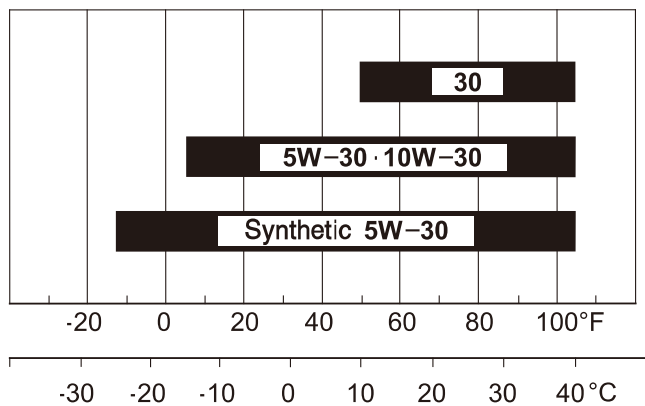

AMBIENT TEMPERATURE

SAE 10W-30 or 5W-30 is recommended for general use. Use a full synthetic 5W-30 for starting/operating temperatures between 5°F (-15°C) and -13°F (-25°C). Other viscosities shown in the chart may be used when the average temperature in your area is within the indicated range.

ENGINE SERVICING

All engine servicing must be performed in accordance with the Engine Manufacturer's handbook provided with the machine. FAILURE TO ADHERE TO THIS MAY INVALIDATE WARRANTY AND/OR SHORTEN THE LIFE OF THE ENGINE.

CHECK HOSES

All the hydraulic hoses should be regularly inspected for chafing and leaks. The hydraulic system is pressurized to 150 Bar and thus the equipment containing it must be kept in good condition.

Identify the hoses that run to the top motor. These have the highest chance of damage as they are constantly moving. If any hydraulic components are changed new seals should be installed during reassembly. Fittings should then be retightened.

TROUBLESHOOTING

Problem	Cause	Remedy
Engine fails to start	<ol style="list-style-type: none"> 1. Spark plug wire is disconnected. 2. Out of fuel or stale fuel. 3. Engine and/or Fuel valve is not in ON position. 4. Choke lever is not in CLOSE position. 5. Blocked fuel line. 6. Fouled spark plug. 7. Engine flooding. 	<ol style="list-style-type: none"> 1. Attach spark plug wire securely to spark plug. 2. Fill with clean, fresh gasoline. 3. Engine and Fuel valve must be in ON position. 4. Choke lever must be in CLOSE position for a cold start. 5. Clean fuel line. 6. Clean, adjust gap, or replace. 7. Wait a few minutes to restart, but do not prime.
Engine runs erratically	<ol style="list-style-type: none"> 1. Spark plug wire is loose. 2. Unit running with Choke lever in CLOSE position. 3. Blocked fuel line or stale fuel. 4. Vent plugged. 5. Water or dirt in fuel system. 6. Dirty air cleaner. 7. Improper carburetor adjustment. 	<ol style="list-style-type: none"> 1. Connect and tighten spark plug wire. 2. Move choke lever to OPEN position. 3. Clean fuel line. Fill tank with clean, fresh gasoline. 4. Clear vent. 5. Drain fuel tank. Refill with fresh fuel. 6. Clean or replace air cleaner. 7. Refer to engine manual.
Engine overheats	<ol style="list-style-type: none"> 1. Engine oil level low. 2. Dirty air cleaner. 3. Air flow restricted. 4. Carburetor not adjusted properly. 	<ol style="list-style-type: none"> 1. Fill crankcase with proper oil. 2. Clean air cleaner. 3. Remove housing and clean. 4. Refer to engine manual.
Chipping action seems too slow, cutting disk stalls, or no material is discharged when engine is running	<ol style="list-style-type: none"> 1. Engine speed is too slow causing belt to slip. 2. Drive Belt is loose or damaged. 3. Knives are dull or damaged. 4. Cutting disk is jammed by debris from the feed hopper and discharge chute. 5. Discharge chute is clogged. 	<ol style="list-style-type: none"> 1. Run the engine at full throttle. 2. Tighten or replace drive belt. 3. Sharpen or replace knives. 4. Remove any built-up debris and turn cutting disk with a wooden stick to be sure it turns freely. 5. Clean out debris.

Problem	Cause	Remedy
The belt frays or rolls over the pulley	<ol style="list-style-type: none">1. Rotor drive pulley groove may be nicked.2. Drive belts may be stretched.3. Pulleys may be misaligned.	<ol style="list-style-type: none">1. Check drive belts for wear and hard spots. File off any nicks on the pulley.2. Replace drive belts.3. Adjust pulleys.
When chipping, branch seems to vibrate and move about excessively with unusual noise	<ol style="list-style-type: none">1. Knives are dull or damaged.2. Knives are not properly seated on the cutting disk.3. The gap between the knives and wear plate is too large.4. Rotor is overloaded with material.	<ol style="list-style-type: none">1. Sharpen or replace knives.2. Loosen the knife mounting screws, reset the knives, and tighten the screws.3. Adjust the gap.4. Allow unit to clear itself before adding more material to the hopper.
Chipper Knives are hitting the wear plate	The gap between the knives and wear plate is set incorrectly.	Adjust the gap.
The machine's wheels track left or right while being towed	Low tire pressure.	Add air to tires.

MechMaxx

info@mechmaxx.com